

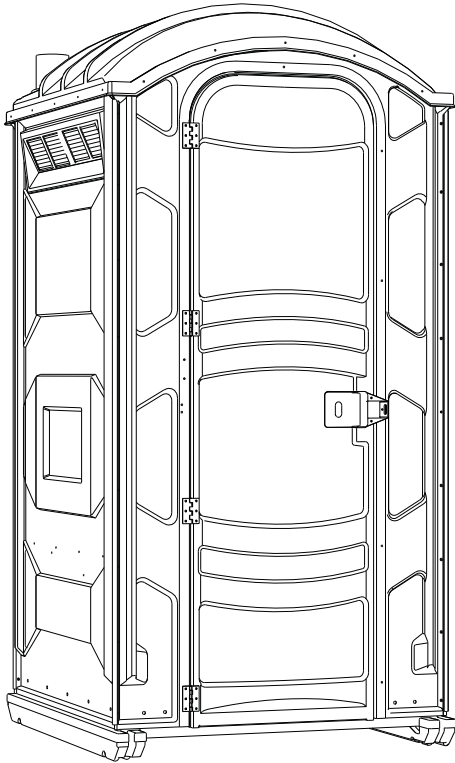

PJN3 Series Assembly Instructions

US PATENTS: 4,577,351 4,637,299 4,793,100 4,895,400



SPECIFICATIONS

DIMENSION	IMPERIAL	METRIC
Exterior Height	91.0 in	231 cm
Interior Height	82.0 in	208 cm
Exterior Width	43.5 in	110 cm
Interior Width	41.0 in	104 cm
Exterior Length	47.0 in	119 cm
Interior Length	41.0 in	104 cm
Holding Tank	60.0 gal	227 ltr
Seat Height	19.0 in	48 cm
Weight (plastic base skid)	165.0 lb	74.25 kg
Weight (wood base skid)	189.0 lb	85 kg
Side Panel Decal Area	12 in x 23 in	30 cm x 58 cm
Door Panel Decal Area	16 in x 21 in	40 cm x 53 cm
Optional Sink Tank Capacity	15 gal	56.8 ltr
Optional Recirculating Flush Tank Capacity	35 gal	132 ltr

For product identification, the serial number is located on the left inside surface (as viewed from the front) of the door jamb, near the door closure clip.

We recommend reading through the entire Assembly Instructions prior to proceeding with installation, service or maintenance. All references to left and right throughout this guide are as viewed from the front.

POLYJOHN USA

PolyJohn Enterprises Corp
2500 Gaspar Ave.
Whiting, IN 46394
Phone: 800-292-1305
Fax: 219-659-0625
www.polyjohn.com
info@polyjohn.com

POLYJOHN WORLDWIDE

PolyJohn (UK) Ltd.
Equinox 1 Audby Lane
Wetherby, England LS22 7RD
Phone: 44 (0) 1937-583333
Fax: 44 (0) 1937-583322
www.polyjohn.co.uk
sales@polyjohn.co.uk

POLYJOHN CANADA

PolyJohn Canada
P.O. Box 2300
199 Forest Plain Rd.
Orillia, Ontario LV3 6S2
Phone: 800-465-9590
Fax: 705-325-8250
www.polyjohncanada.ca
info@polyjohncanada.ca

GENERAL OVERVIEW

- When using air operated screw drivers or impact wrenches, be sure that the torque setting does not exceed 28 inch pounds.
- When using a battery-operated drill, set it to the lowest torque setting.
- Please follow the instructions in the order they are presented. It is suggested that you read through the entire assembly instructions prior to proceeding with the assembly.
- All references to left, right, front and rear throughout the entire assembly instructions are as viewed from the front of the restroom.
- All rivet holes drilled 13/64" dia.
- Use 1/4" disposable shim strips.
- The **PJN3 Model** restroom assembly will require two people.
- These instructions are for restrooms shipped unassembled. If you receive assembled units, please retain these instructions for maintenance and repair purposes.
- We strongly suggest that these restrooms, as with all portable structures, be transported and handled with care. Dropping the restroom when loading and unloading could cause damage to the door jamb and other components.

FULL SIZE SCALE FASTENER DRAWINGS

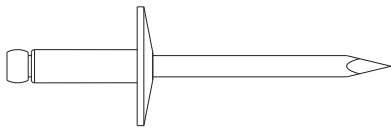

(69) PC-000100 Rivet
Large Flange, Short

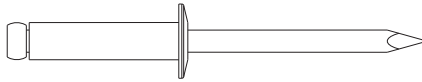

(2) PC-000104 Rivet
Small Flange, Long

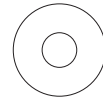

(80) PC-000106 Washer
3/16" Back-up

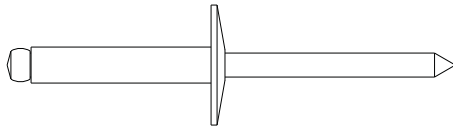

(2) PC-000101 Rivet
Large Flange, Long

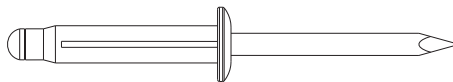

(4) PC-000105 Rivet
Small Flange, Hollow Wall

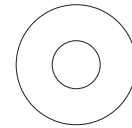

(4) PC-000123 Washer
1/4" x 5/8" Flat

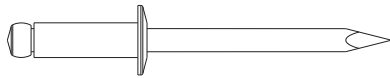

(2) PC-000102 Rivet
Small Flange, Short

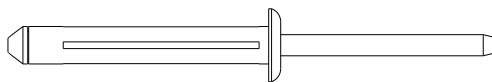

(1) PC-000117 Rivet
Small Flange, Long Hollow Wall

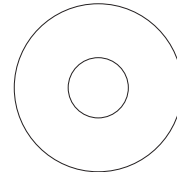

(1) PC-000168 Washer
5/16" x 7/8" Flat

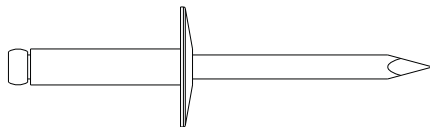

(8) PC-000103 Rivet
Large Flange, Medium

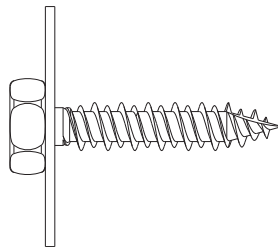

(19) PC-000192 Sems Assembly
1/4" x 1-1/4" Self Tapping



(4) PC-000140 Nut
1/4"-20 Nylok

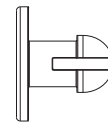

(4) PC-000367 Fastener
Nylon Push

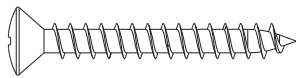

Optional - PC-000158
Self Tapping Screw
(1) Used in PSN1 Sink

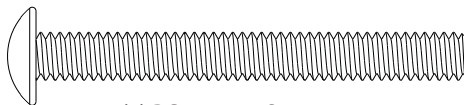

(4) PC-000122 Screw
1/4"-20 x 2-1/4" Long

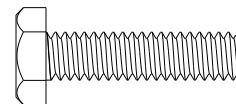

Optional - PC-000139
Bolt, 1/4"-20 x 1"
(1) Used in FT02-1000
Recirculating Tank

~~TOOLS REQUIRED FOR ASSEMBLY~~

- | | | | |
|---|---|--|---|
| <ul style="list-style-type: none"> • Drill • 13/64" Drill Bit • Marker | <ul style="list-style-type: none"> • Rivet Gun with 3/16" tip • Phillips Cross-head Screwdriver • Carpenters' Square | <ul style="list-style-type: none"> • Hammer • Pliers • Tape Measure | <ul style="list-style-type: none"> • Socket Wrench • Vise-Grips • 7/16" Socket |
|---|---|--|---|

ASSEMBLY INSTRUCTIONS

STEP 1. DOOR JAMB AND FRONT ASSEMBLY TO BASE SKID:

Refer to Figure 1. To assemble the door jamb to the skid, stand two waste tanks on end about four feet apart (as shown). Stand a base skid with the tank space toward the ground and the four holes on the floor side of the base skid up. Position the front assembly on top of the tanks with the bottom of the front assembly resting on the base skid. (You may need to add a 4" x 4" on the tank at the top of the front assembly to level the top with the base skid). Cut the strap holding the door closed. Open the door and install a PC-000104 rivet into the hole where the cut strap went through the door jamb. Use a carpenter's square to align the hinged leg of the door jamb with the base skid so the door hangs square. The distance between the two legs of the door jamb is 24". Match up the four holes in the door jamb with the four slots in the base skid. Fasten the door jamb to the base skid with (4) PC-000122 screws, (4) PC-000123 washers, and (4) PC-000140 nuts using a Phillips cross-head screwdriver and a 7/16" socket wrench. Drive (4) PC-000192 sems lag screws through the two holes on the left and right sides of the front panel into the base skid. **CAUTION: DO NOT OVER-TIGHTEN; TIGHTEN ONLY UNTIL SNUG.** Stand the skid and front assembly upright.

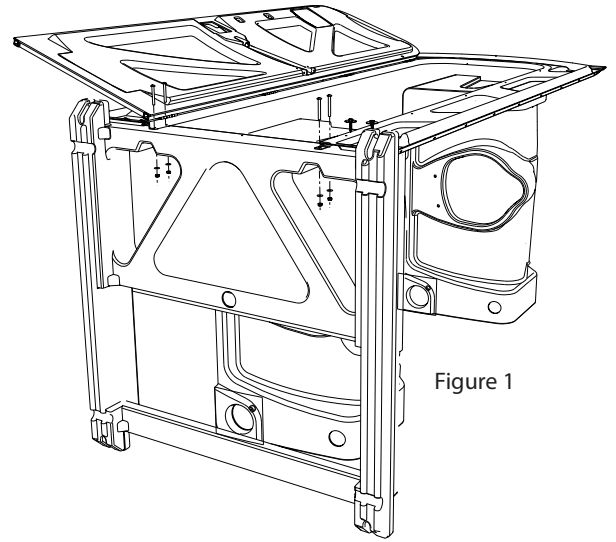
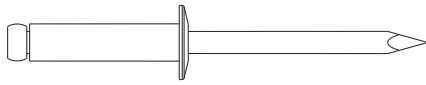
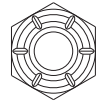

Figure 1



PC-000104 Rivet
1 Used in this step



PC-000140 Nut
4 Used in this step

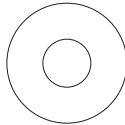

PC-000123 Washer
4 Used in this step

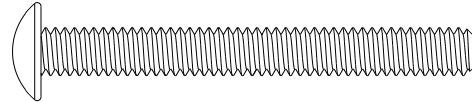

PC-000122 Screw
4 Used in this step

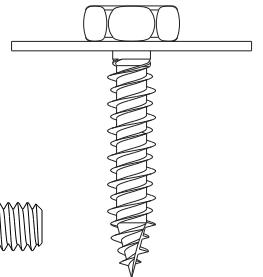

PC-000192 Sems
4 Used in this step

STEP 2. CORNER MOLDINGS TO SIDE PANELS:

Refer to Figure 2. Place a wall panel on top, and on the sides of the tanks. The mitre cut end of the corner moldings go towards the top of the side panel. Slip the corner moldings onto the edges of the side panel. Lift and insert an edge of a side panel into the grooves of the corner moldings. Insert awls into the second hole of the top and bottom edges to hold the panel and moldings in place. (The corner moldings and each edge of the side panels have nine holes. The center hole is 1/4" diameter and the remaining holes are 5/16" diameter. The bodies of the rivets are 3/16" diameter. This allows for thermal expansion and contraction of the cabana during outdoor temperature fluctuations.) **NOTE: Drive all rivet heads from the front of the restroom, to give the unit a uniform visual appearance.** Rivet the 1/4" center hole first using a PC-000100 rivet and a PC-000106 back-up washer. Repeat for the remaining holes, then stand the three side panels and two corner moldings upright.

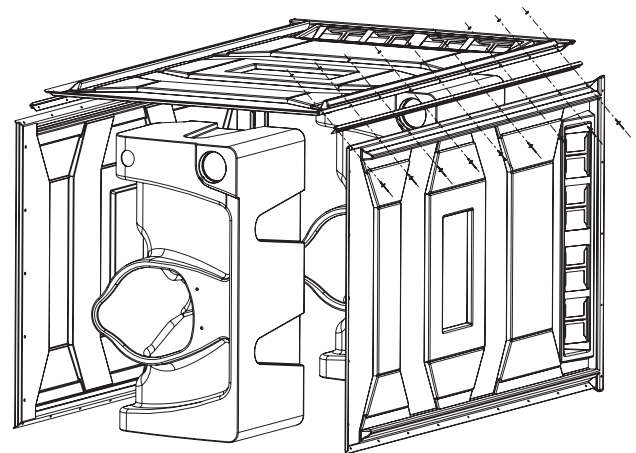
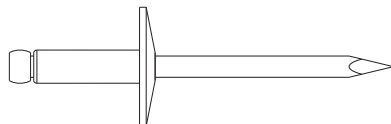
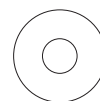

Figure 2



PC-000100 Rivet
18 Used in this step



PC-000106 Washer
18 Used in this step

STEP 3. CABANA ASSEMBLY:

Position the three side panels and corner molding sub-assembly around the base skid. **IMPORTANT - The walls of the cabana should be approximately 1/4" from the top surfaces of the base skid. Place 1/4" thick shims between the rear corners of the cabana, and the base skid; this will make the cabana structure level with the front assembly and allow for thermal expansion and contraction during outdoor temperature fluctuations.** To connect the front assembly, corner moldings, and side panels, begin at the front of the restroom. Insert a PC-000100 rivet through the center hole, while attaching a PC-000106 back-up washer from the back. Repeat for the remaining holes. (For a uniform visual appearance, drive all rivet heads from the front). **CAUTION: DO NOT PRE-DRILL HOLES IN THE BASE SKID; THE PC-000192 SEMS LAG SCREWS ARE SELF-THREADING. DO NOT OVER-TIGHTEN THE SEMS LAG SCREWS; TIGHTEN ONLY UNTIL SNUG.** On the bottom of each wall panel, there are five predrilled holes, begin at the center hole of the rear panel. Use a 7/16" socket wrench, while pushing the rear wall panel against the base skid, drive-in the lag screws. Then continue with the side wall panels, starting with the front edge of each side, working towards the back.

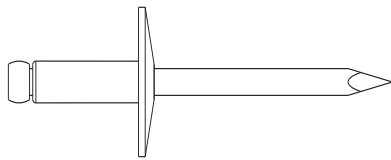

PC-000100 Rivet
18 Used in this step



PC-000106 Washer
18 Used in this step

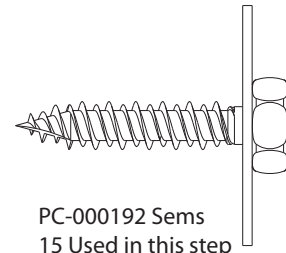

PC-000192 Sems
15 Used in this step

STEP 4. WASTE HOLDING TANK INSTALLATION:

ASSEMBLY OF OPTIONAL RECIRCULATING TANK: For shipping purposes, the pump is fastened under the lid with the necessary parts for final assembly and installation. Use a 7/16" socket wrench to remove the pump from the lid. Attach it to its proper location as illustrated in the exploded view, and attach hoses with #12 hose clamps. The CH100-050 hose connects to the out port on the pump. The CH100-0165 hose connects to the in port on the pump.

INSTALLATION OF STATIC OR RECIRCULATING WASTE TANK: Refer to Figure 3. Position the tank so that it is centered between the left and right side wall panels and pushed up to the floor plate. There are drill spots on each of the side wall panels. The top four in-line drill spots on the rear wall panel are used to rivet the back of the holding tank to the rear wall panel. Of the top four drill spots on each of the side wall panels, only the two closest to the rear are used to rivet the sides of the holding tank to the side wall panels. While pushing the wall panels in flat against the tank, use a 13/64" drill bit. Drill through the specified drill spots of the wall panels into the outer walls of the tank. **CAUTION: DRILL ONLY THROUGH THE OUTER WALL OF THE HOLDING TANK. DO NOT DRILL THROUGH THE INSIDE TOP SURFACES OF THE TANK.** From the outside of the restroom one person will rivet through the drilled holes with PC-000103 rivets, while another person inside the restroom puts PC-000106 back-up washers on the rivet stems.

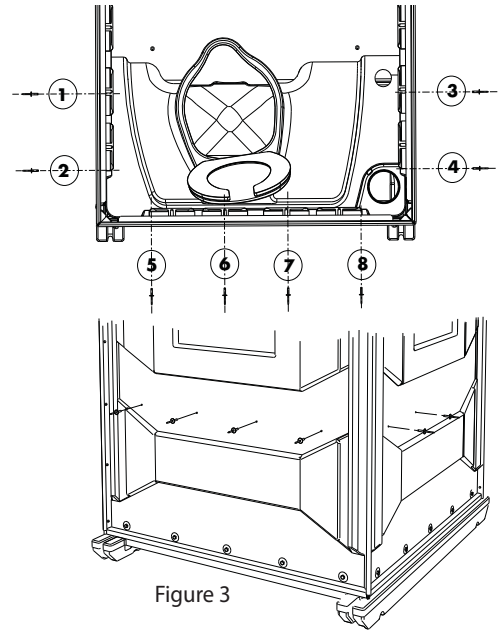
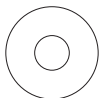
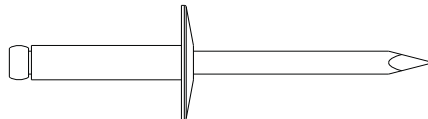

Figure 3



PC-000106 Washer
8 Used in this step



PC-000103 Rivet
8 Used in this step

STEP 5. ROOF INSTALLATION:

Position the roof over the wall panels, make sure the hole for the tank ventilation tube is above the corresponding hole in the holding tank. (The front and three side panels are supplied with predrilled holes at the top center of each panel. The roof is supplied with five predrilled holes on each of the four edges.) Start with the front of the unit. Align the predrilled top center roof holes to the center holes of the wall panels and front assembly. From the outside of the restroom one person will rivet PC-000100 rivets through each of the four top center holes, while another person inside the restroom puts PC-000106 back-up washers on the rivet stems. Next, holding the roof firmly down, using the remaining predrilled holes in the roof, drill 13/64" holes through to the wall panels and front assembly. The person on the outside will again, rivet the PC-000100 rivets through the drilled holes while another person puts the PC-000106 back-up washers on the rivet stems.

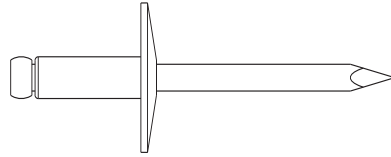

PC-000100 Rivet
20 Used in this step



PC-000106 Washer
20 Used in this step

STEP 6: FLY SCREEN INSTALLATION:

(Each of the three sidewall panels has two vent screens. On the surface of each vent screen there is a date stamp symbol. The symbol goes toward the center of the sidewall panel, facing the inside.)

For each of the three sidewalls, insert one screen from each side of the vent slot and overlap the center holes at the date stamp symbol (as shown in Figure 4).

IMPORTANT - Make sure both screens together are centered in the vent slots. Drill a 13/64" hole through the center hole of the screen and into the sidewall. Rivet the screen in place from the outside using a PC-000100 rivet with a PC-000106 back-up washer on the inside. Using the hole at each end of the screen as a guide, drill 13/64" holes through the vent screens and into the sidewall panels. Rivet the screens in place using PC-000100 rivets on the outside with PC-000106 back-up washers on the inside.

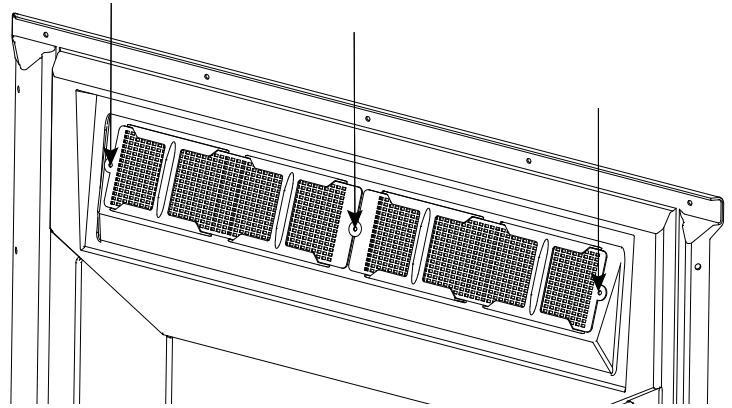
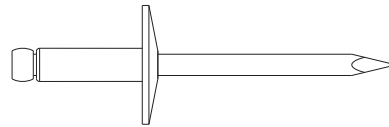
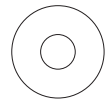

Figure 4



PC-000100 Rivet
9 Used in this step



PC-000106 Washer
9 Used in this step

STEP 7. VENTILATION STACK INSTALLATION:

Force the vent stack up through the 4" diameter hole in the roof. (This is intended to be a tight fit.) Slide the vent stack down and into the 4" diameter recessed hole in the holding tank so that it rests on the round ledge of the hole in the tank. Drill a 13/64" hole through the boss and vent stack. Fasten the vent stack in place with a PC-000117 rivet.

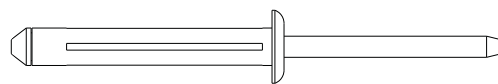

PC-000117 Rivet
1 Used in this step

STEP 8. SLIDE LATCH, DOOR PULL INSTALLATION:

Refer to Figure 5. Follow steps as illustrated.

Figure 5

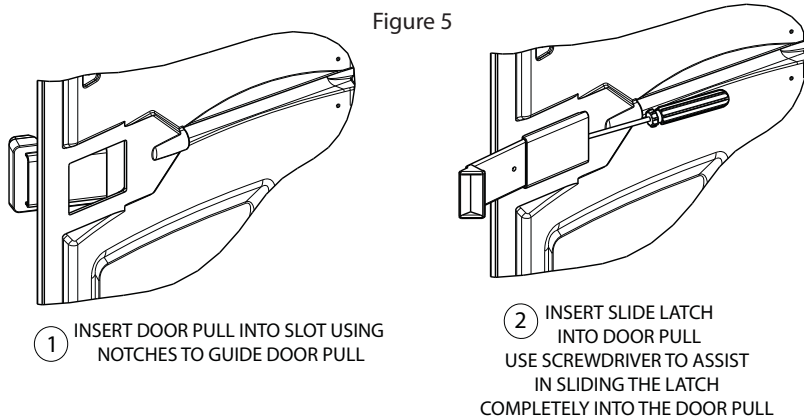

STEP 9. DOOR CHECK CABLE:

There are two holes located on the right inside surface of the door toward the top. Position the metal bracket on the end of the cable so the angle points toward the interior of the restroom. Align the two outer holes of the bracket with the two holes in the door, rivet in place with (2) PC-000102 rivets. Locate the hole at the top, in the middle of the door jamb and from the outside insert a PC-000104 rivet through the jamb. Attach the loop end of the cable, a PC-000168 washer, and a PC-000106 back-up washer on the rivet stem and rivet in place.

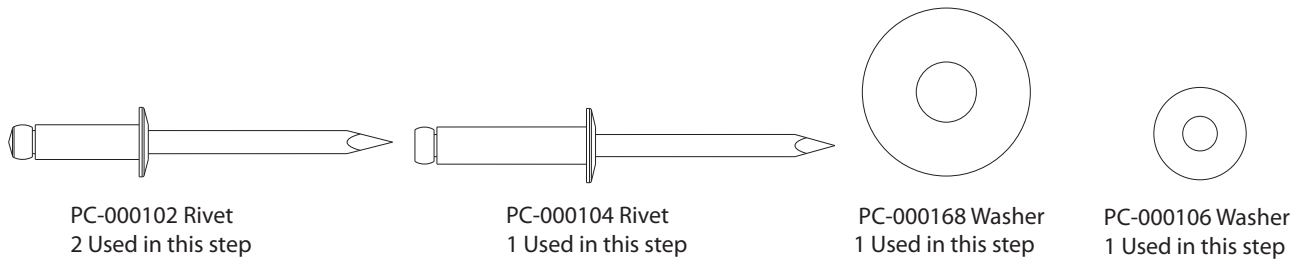

STEP 10. DOOR CLOSURE INSTALLATION:

Refer to Figures 6, 7 and 8. Place the door closure in the molded channel located at the center of the door and push it into the molded pocket. Thread the ball end of the cable through the hole in the door closure retainer clip. Position the door closure retainer clip (as shown in Figure 6). Rivet in place with (2) PC-000105 bulbhex rivets. Go into the restroom and close the door. Place the top of a hammer against the PC-000181 spring cable clip (as shown in Figure 7). Place the end of the spring cable in the claw of the hammer. Open the door while holding the hammer in position. Hold the door open with your foot and clamp a vice-grips pliers on the cable where it comes out of the door (as shown in Figure 8). **BE SURE TO CLAMP DOWN TIGHT.** Remove the cable from the claw of the hammer, close the door, and place the end of the cable into the slot of the cable clip. Open the door and remove the vice-grips.

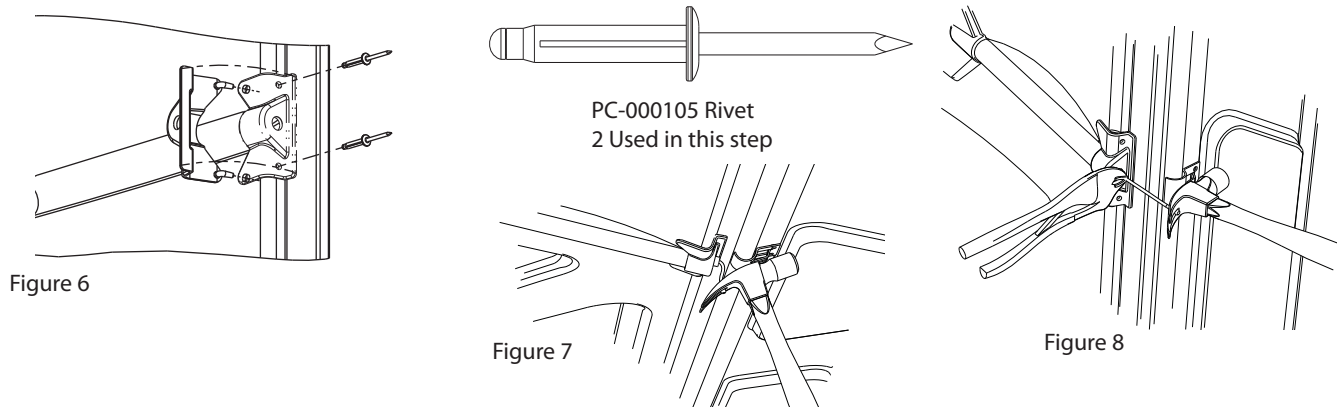

STEP 11. TOILET SEAT INSTALLATION:

Push the lid onto the seat (*lining up the holes of the lid with those in the seat*). Line up the holes of the hinge bolts with those in the seat/lid. From the outer edge, push the pins through the holes until flush. Place the seat/lid on to the tank (*inserting the bolts through the holes in the tank*). Use pliers to tighten the nuts.

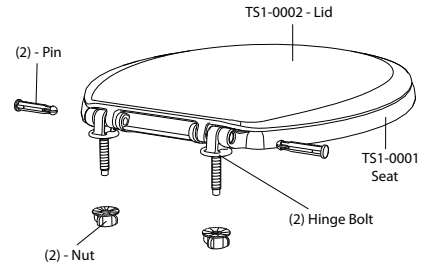

STEP 12. URINAL INSTALLATION:

OMIT THIS STEP IF OPTIONAL SINK IS BEING INSTALLED ON THE LEFT SIDE WALL. Refer to Figure 9. Insert the drain spigot of the urinal into the hole on the left top surface of the holding tank. Position the urinal so that it is level. There are two impressions at the top of the urinal. Drill 13/64" holes in the center of these two impressions and through the side wall panel. From inside of the restroom one person will rivet through the drilled holes with PC-000101 rivets, while another person outside the restroom places PC-000106 back-up washers on the rivet stems.

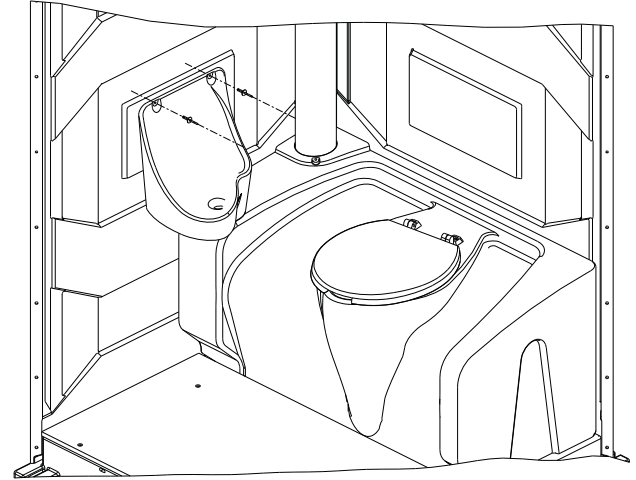
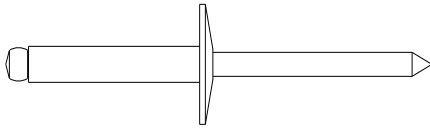
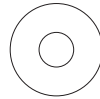

Figure 9



PC-000101 Rivet
2 Used in this step



PC-000106 Washer
2 Used in this step

STEP 13. TOILET PAPER DISPENSER INSTALLATION:

The double roll dispenser is mounted up on the right wall panel. Position the dispenser on the top edge of the second raised panel directly below the fly screens at the desired location. (*If sink is installed on the right wall, position the dispenser towards the rear of the panel*). **CAUTION: BE SURE THE LOCATION OF THE DISPENSER IS NOT IN THE WAY OF PERSONS USING THE RESTROOM.** Level the dispenser on the wall. Using the holes in the back of the dispenser as a guide, mark the locations for the drill holes with a marker. Drill four 13/64" holes into the drill spots marked. From the outside rivet into the holes just drilled with (4) PC-000100 rivets while someone places (4) PC-000106 back-up washers onto the rivet stems on the inside.

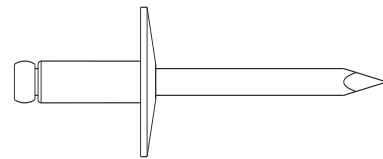

PC-000100 Rivet
4 Used in this step

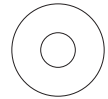

PC-000106 Washer
4 Used in this step

STEP 14. MIRROR:

The mirror is mounted into the square recess on the inside of the door with (4) PC-000367 nylon push rivets.

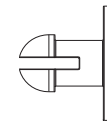

PC-000367 Fastener
4 Used in this step

STEP 15. CONVENIENCE HOVER HANDLE:

The convenience handle is mounted into the two square recesses on the inside of the door with (2) PC-000105 bulbex rivets.

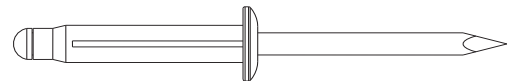

PC-000105 Rivet
2 Used in this step

Overview of Optional Sink Installation

The sink bowl is attached to the sink tank with (2) PC-000107 rivets that act as hinges. There is an internal spring snap button located on the top right side of the bowl, which will hold the bowl in the up position for service and maintenance. To lower the bowl, simply depress the snap button.

To Open the Sink Top (follow instructions as illustrated on the right)

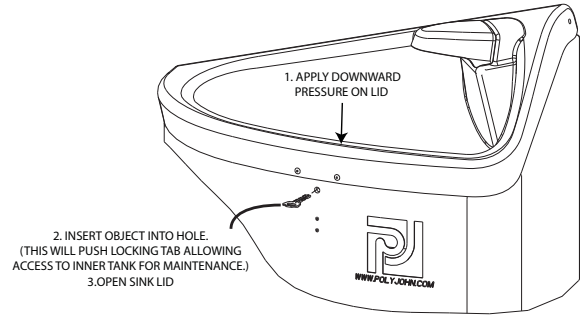

OPTIONAL SINK - INSTALLATION

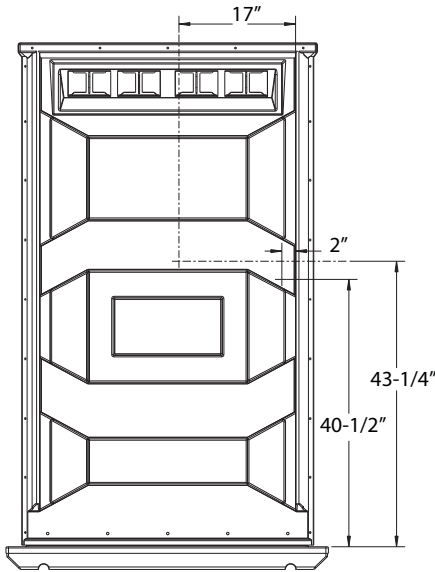

Left Wall Installation

Refer to Illustrations. Before installing the sink, a 1-1/8" drain hole that will accept the drain hose must be cut in the waste tank. This hole should be located on the top left front edge of the waste tank approximately 16-1/2" up from the floor. (As shown on the right, a 2-1/2" plug PC-000557, is available to cover the urinal drain hole.) **NOTE: Make sure the drain hole your cutting as indicated above is just below the urinal hole.** From the exterior, drill two 13/64" holes (as shown on the left) through the sidewall and the back of the sink, be sure the sink is pressed flat against the sidewall. Fasten the sink to the side from the exterior with (2) PC-000103 rivets and (2) PC-000106 back-up washers on the inside of the sink. **Attach sink to base skid:** Drive (1) PC-000158 self-tapping screw in the pre-drilled hole in the sink mounting plate. Perform a system check by adding a few gallons of water to the sink. Depress the pump a few times to "prime" it. The pump has a built in check valve that will hold the prime between uses.

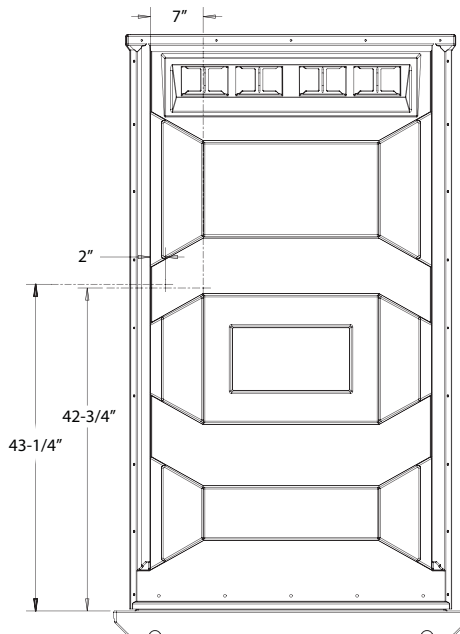
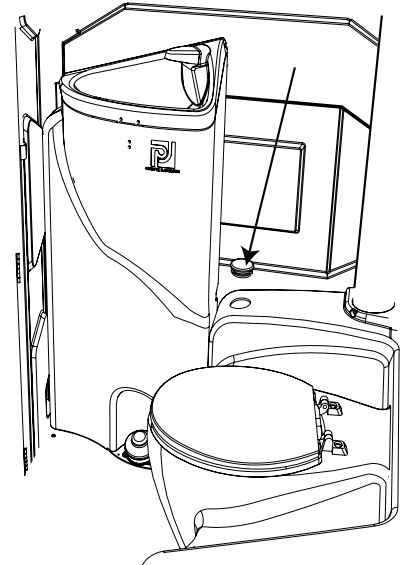

Right Wall Installation

Before installing the sink, a 1-1/8" drain hole that will accept the drain hose must be cut in the waste tank. This hole should be located on the top right front edge of the waste tank approximately 15-1/2" up from the floor.

From the exterior, drill two 13/64" holes through the sidewall and the back of the sink (as shown on the left) be sure the sink is pressed flat against the sidewall.

Fasten the sink to the side from the exterior with (2) PC-000103 rivets and (2) PC-000106 back-up washers on the inside of the sink. **Attach sink to base skid:** Drive (1) PC-000158 self-tapping screw in the predrilled hole in the sink mounting plate. Perform a system check by adding a few gallons of water to the sink. Depress the pump a few times to "prime" it. The pump has a built in check valve that will hold the prime between uses.

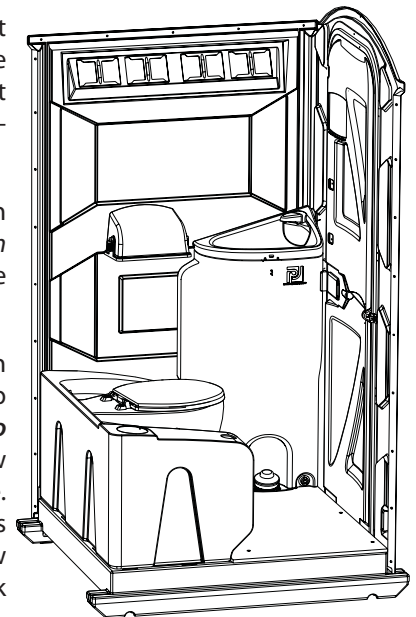

Winterizing Sink (if installed)

- Drain all water from the tanks.
- Depress the foot pump to clear lines.
- Flush tank with a solution of chlorine and water.

OPTIONAL ACCESSORIES

CK01-0164 - Hand Sanitizing Dispenser
LK04-1000 - Door Lock Clip & Hasp Kit
PSN1-1000 - Single User Hand Wash Sink
TD04-1000 - PJ Paper Towel Dispenser

FD1-1000 - Hand Foam Dispenser
LS04-0001 - Liquid Soap Dispenser
PT01-1000 - Toilet "Tug-A-Long"
TU01-1000 - Single Trailer

FT02-1000 - Recirculating Flushing System
MS02-1000 - Lifting Sling Set for Plastic Skid
SU01-0001 - Convenience Shelf w/Coat Hook
TU02-1000 - Double Trailer

CLEANING AND MAINTENANCE

Use a mild soap to clean all surfaces and component parts.

Minor scratches and abrasions can be lightly sanded or scrubbed with a mild abrasive cleaner (such as "Soft Scrub") that contains calcium carbonate, hypochlorate bleach and detergents. Be sure to follow the cleaning product directions since these ingredients may cause hazardous gases when mixed with other chemicals. Rinse the cleaned area and buff with a conventional wax.

Some light scratches may also be hidden by using an industrial hot air gun.

If sink is installed add a "Fresh Sink Tablet" (chlorinated tablet) each time the sink is filled with water to keep the water fresh.

For a source of cleaning, deodorizing and paper products contact:

RID IT
2500 GASPAR AVE.
WHITING, IN 46394-2175
800-292-1305 EXTENSION 514
www.rid-it.com

We highly recommend membership in the Portable Sanitation Association International (PSAI); the worldwide authority on portable sanitation services. The PSAI, "Portable Sanitation Industry Certification Program" manual contains a wealth of information on standards and service procedures. For more information contact the PSAI:

PORTABLE SANITATION ASSOCIATION INTERNATIONAL (PSAI)
7800 METRO PARKWAY, SUITE 104
BLOOMINGTON, MINNESOTA 55425 USA
800-822-3020 / 612-854-8300 FAX 612-854-7560
www.pesai.org

OUR MISSION STATEMENT

"PolyJohn is a family owned, state of the art, plastics manufacturing company dedicated to providing its employees with a work environment committed to excellence, and its customers with innovative products, services and technology that meet or exceed their requirements."

THANK YOU FOR PURCHASING POLYJOHN PRODUCTS!

Look for us on the Web @ www.PolyJohn.com