



We'll Care III™ Assembly Instructions

U.S. PATENTS: 5,682,622 D384,751

SPECIFICATIONS

Dimension	Imperial	Metric
Exterior Height	92.5 in	235 cm
Exterior Width	85.2 in	216 cm
Exterior Length	92.4 in	235 cm
Door Frame Height (I.D.)	80 in	203 cm
Door Frame Width (I.D.)	32.75 in	83 cm
Seat Height	19 in	48 cm
Interior Turning Circle	60 in	152 cm
Grab Bar Height	33 in	84 cm
Threshold Height	.5 in	1.2 cm
Side Wall Panel Decal Area	6" x 37"	15cm x 94cm
Tank Capacity:		
Static	50 gal	189 L
Recirculating	34 gal	129 L
Weight (Static)	395 lbs	179 kg

We recommend reading through the entire Assembly Instructions prior to proceeding with installation, service or maintenance. All references to the left and right throughout this guide are as viewed from the front.



~~Tools Required for Assembly~~

- Rivet Gun
- Hammer
- Rubber Mallet
- Drill
- 13/64" (5.33mm) Drill Bit
- 1/2" (12.70 mm) Wrench
- Vise-grips
- Phillips Screwdriver
- Tape Measure
- Paper Clip
- 2 - 1/4" (57.15mm) Hole Saw
- 7/16" (11.17mm) Wrench

POLYJOHN USA

PolyJohn Enterprises Corp
2500 Gaspar Ave.
Whiting, IN 46394
Phone: 800-292-1305
Fax: 219-659-0625
www.polyjohn.com
info@polyjohn.com

POLYJOHN WORLDWIDE

PolyJohn (UK) Ltd.
Equinox 1 Audby Lane
Wetherby, England LS22 7RD
Phone: 44 (0) 1937-583333
Fax: 44 (0) 1937-583322
sales@polyjohn.co.uk

POLYJOHN CANADA

Rama Plastics
P.O. Box 2300
199 Forest Plain Rd.
Orillia, Ontario LV3 6S2
Phone: 800-465-9590
Fax: 705-325-8250
info@ramaplastics.ca

Elevation View ADA - Requirements

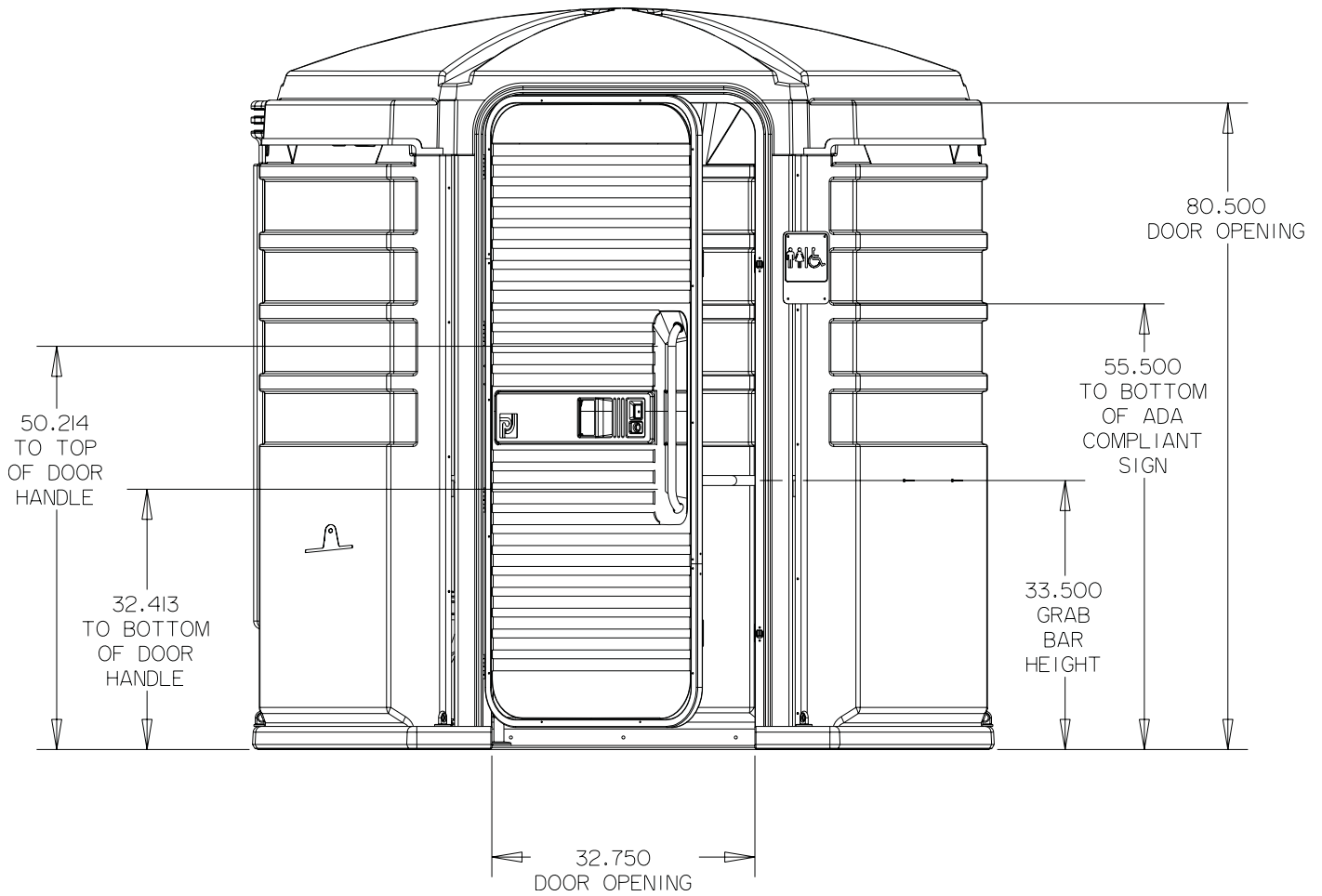

Floor Plan ADA - Requirements

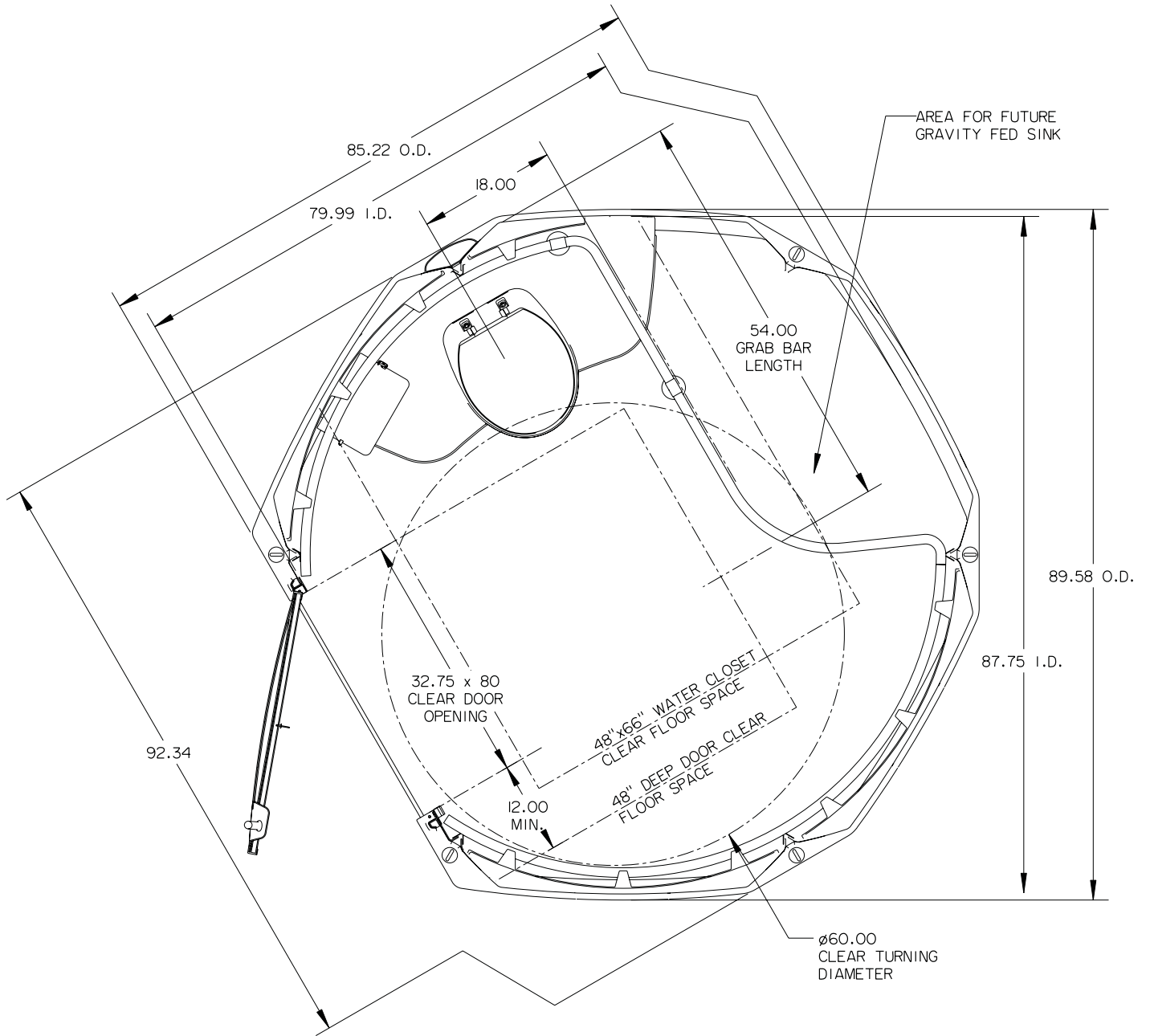

We'll Care III™

An Americans with Disabilities Act (ADA) Compliant Restroom

The **We'll Care III Model Restroom Assembly** will require two people. It is suggested that you read through the entire assembly instructions and review the exploded parts drawing prior to proceeding. All references to the left and right throughout this guide are as viewed from the front. Please save these instructions for future reference.

Full Size Scale Fasteners

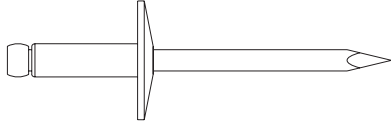

(4) PC-000100 - Rivet

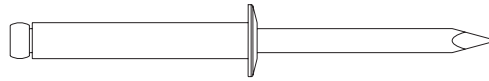

(4) PC-000107 - Rivet

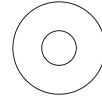

(51) PC-000106 - Washer

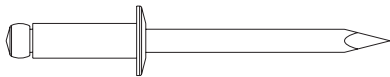

(90) PC-000102 - Rivet

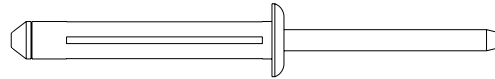

(25) PC-000117 - Rivet

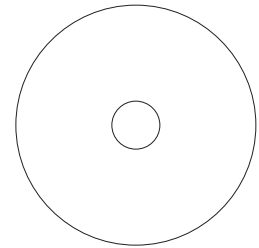

(49) PC-000121 - Washer

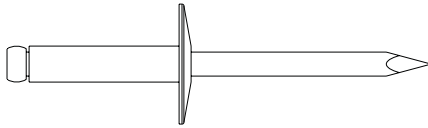

(16) PC-000103 - Rivet

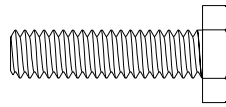

(2) PC-000139 - Bolt

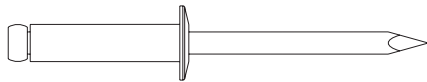

(49) PC-000104 - Rivet

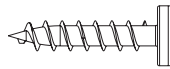

(6) PC-000163 - Screw

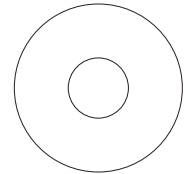

(1) PC-000168 - Washer

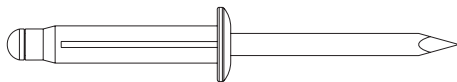

(18) PC-000105 - Rivet



(2) PC-000166 - Screw

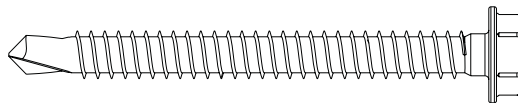

(5) PC-100175 - Screw

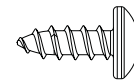

(4) PC-000195 - Screw

Assembly Instructions

STEP 1: Joint Extrusions to Wall Assembly

There are five wall panels and six wall joint extrusions (*each wall joint extrusion has five pre-drilled holes on each side*). Insert a wall panel into the slot of a wall joint extrusion and rivet in place with (5) PC-000102 rivets. Insert the next wall panel into the slot on the other side of the wall joint extrusion and rivet into place with five more PC-000102 rivets. Repeat until shell is done.

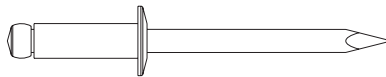

PC-000102 Rivet
(50) Used in this step

STEP 2: Walls to Door Connecting Panel

There are two door connecting panels. Insert the left panel fully into the slot of the left wall joint extrusion (*making sure the top ledge of the door connecting panel is in line with the top of the wall joint extrusion*). Using a 13/64" drill bit, drill through the pre-drilled holes of the wall joint extrusion into the door connecting panel. Rivet into place with (5) PC-000102 rivets. Repeat for the right side.

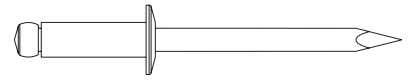

PC-000102 Rivet
(10) Used in this step

STEP 3: Door Jamb to Floor

Raise the floor assembly so it can be accessed from the underside. Remove the (2) PC-000164 bolts, (2) PC-000123 washers, (2) PC-000121 washers and (2) PC-000141 nylok-nuts located on each side of the door opening. Place the jamb into the corresponding recess of the base surround (*make sure the welded feet of the door jamb sit in between the base surround and the floor*). Line up the holes and re-insert the bolts, washers and nuts and tighten.

STEP 4: Align Rubber Seal

Starting on the left side of the door jamb, align the foam rubber seal SA1-0025 along the inside edge of the base surround. Make sure to lay the flap of the rubber seal on top of the base surround with the crease pressed against the edge of the inner wall of the base surround. Remove the backing of the rubber seal a little at a time while pressing the adhesive edge of the rubber seal against the inner wall of the base surround. Lower the unit back to the ground.

STEP 5: Placing Walls Inside Base Surround

Place the wall assembly around the inside of the base surround, making sure the rubber seal stays up along the top of the base surround.

STEP 6: Walls/Door Connecting Panel to Door Jamb

Align one side of the wall/door connecting panel assembly (*created in step 2*) to one side of the door jamb (*the door connecting panels may be short and will not always sit flush to the surface of the floor plate*). From inside drill through the pre-drilled holes of the door jamb through the door connecting panel. Rivet into place with (5) PC-000104 rivets.

NOTE: Do not rivet the center two holes on the left side of door jamb at this time, these holes are for the cable clip. Repeat for the other side of the door jamb.

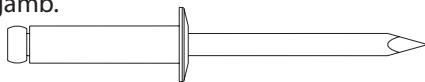

PC-000104 Rivet
(10) Used in this step

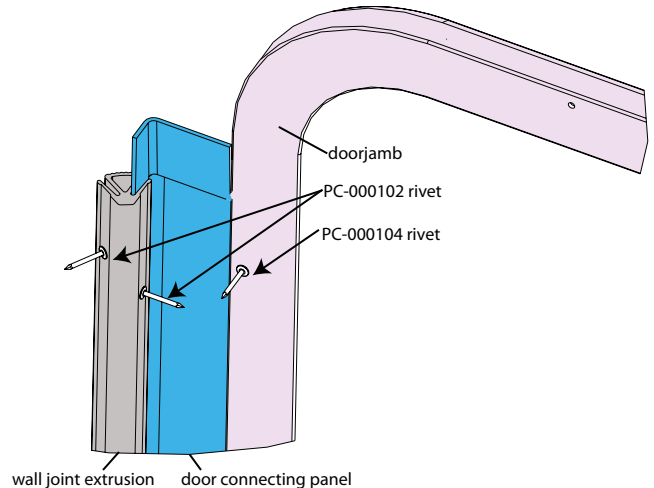

STEP 7: Walls to Base Surround

NOTE: At the bottom center of each wall panel there are three pre-drilled holes. The corners of the wall panels are angled and do not have pre-drilled holes. Drill holes through the first wall of the base surround only. Starting with the left wall panel (*panel 1*), using a 13/64" bit, drill a hole in the bottom center of the left corner of the wall panel into the base surround (*making sure the height is level with the height of the holes that are in the bottom center of the wall panel*). While pushing the corner against the base surround, rivet in place using a PC-000117 rivet with a PC-000121 washer behind the head of the rivet. Repeat for the right corner. Drill through the pre-drilled holes of the wall panel into the base surround. While pushing the wall panel against the base surround, rivet the wall in place using (3) PC-000117 rivets with (3) PC-000121 washers behind the heads of the rivets. Repeat for the remaining four walls.

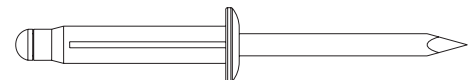
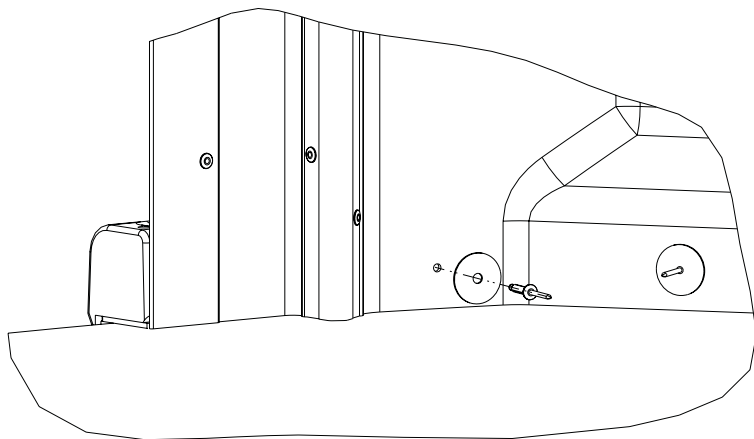

PC-000117 Rivet
(25) Used in this step

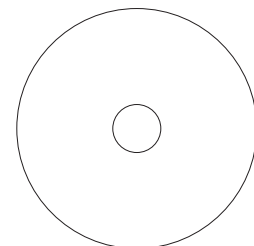

PC-000121 Washer
(25) Used in this step

STEP 8: Grab Bar Support Clips

Starting with the left wall joint extrusion (*before panel 1*) measure up from the floor 31". Place the straight edge of the grab bar support clip facing downward at the 31". Using the clip as a drill guide, drill through the four holes of the clip into the wall joint extrusion. Rivet the clip in place with (4) PC-000104 rivets. Repeat for all other wall joint extrusions except for the one between panels 2 & 3. **IMPORTANT: THE WALL JOINT IN THE REAR LEFT CORNER OF THE UNIT (BETWEEN PANELS 2 & 3) WILL NOT GET A SUPPORT CLIP. MAKE SURE THE STRAIGHT EDGE OF THE SUPPORT CLIPS FACE DOWNWARD.**

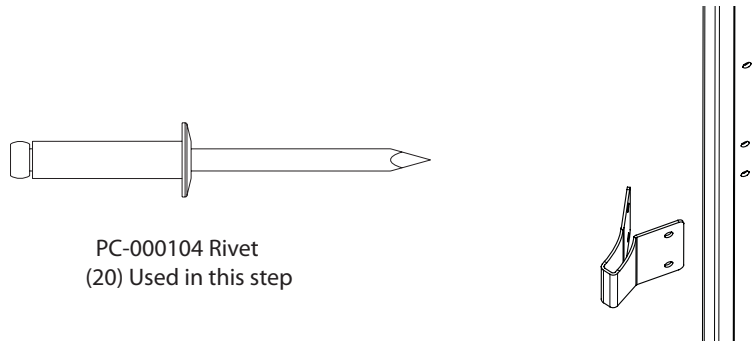

STEP 9: Tank

Place the waste tank inside the unit into position so that the tank is centered on the left middle wall joint (*between the first two left wall panels, 1 & 2*). On the outside of both side walls, measure up 14" from the top of the base surround, and measure out from the corners on each of the wall panels, marking locations at 2-1/2" and at 17". While someone inside pushes the tank against the wall panels, on the outside using a 13/64" bit, drill through the spots just marked into the tank. Rivet the tank in place using (4) PC-000103 rivets from the outside with (4) PC-000106 back-up washers placed on the inside of the tank.

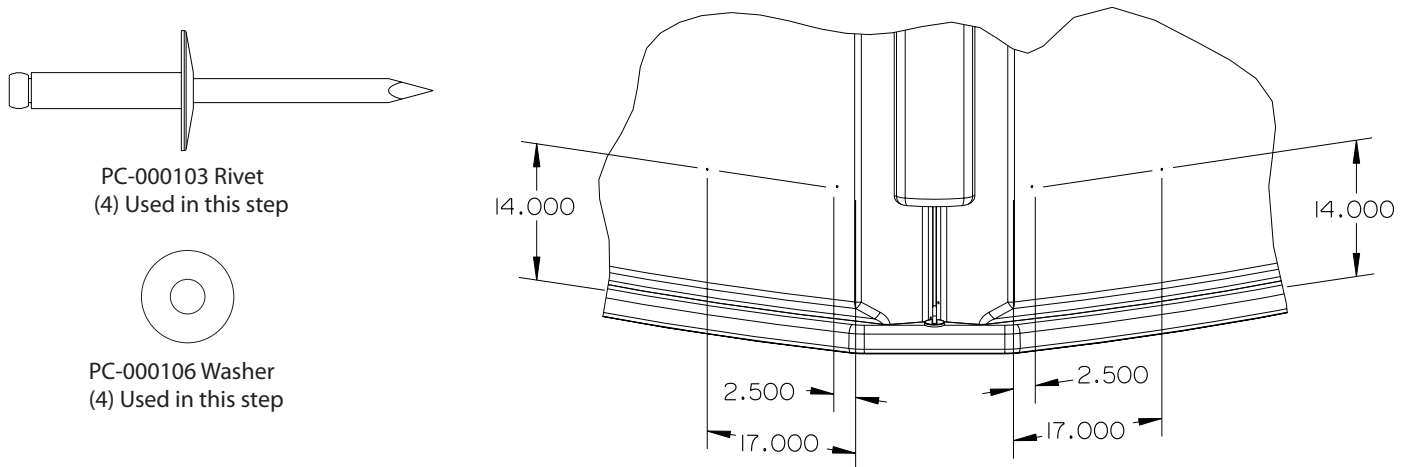

STEP 10: Fly Screens

Hang the large fly screens (SG1-0035) in place from the outside by tilting them outward and attaching the slots of the screens onto the corresponding lip at the top of the wall panels (*as shown*). From the inside, pull the screens inward into an upright position. Use a 13/64" drill bit and drill through the pre-drilled holes of the fly screens into the wall panels. From inside rivet each screen into place with (1) PC-000102 rivet and (1) PC-000106 back-up washer on the outside.

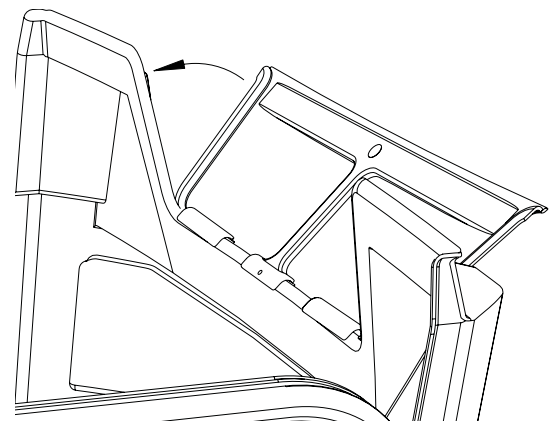
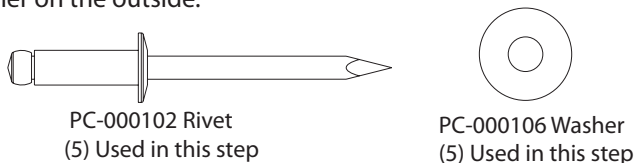

STEP 11: Roof

Roof to Door Jamb:

Bend and flex the corners of the roof inward (*helps to ease the roof over the walls*). Lift the roof and place it on the unit (*resting along the top ledge of the walls, with the arch for the door over the door jamb, make sure the walls and fly screens are tucked on the inside of the roof*). Slide the front lip of the roof in the slot on the inside of the door jamb and pull the roof down as far as it will go (*a rubber mallet may be used to help align*). Using a 13/64" drill bit, drill four holes into the pre-drilled holes located in the top of the door jamb through the roof. Rivet in place with (4) PC-000104 rivets.

Front Corners to Roof:

From outside, center and drill a hole right above the lip on the front of the roof, through to the front wall on each side of the door jamb (*as shown*). Rivet in place on both sides of the door jamb using a PC-000103 rivet from the outside with a PC-000121 washer and a PC-000106 back-up washer on the inside.

Wall Panels to Roof:

NOTE: From inside the unit, push the wall panels out so that the wall panels are tight against the roof. Using a 13/64" bit, drill through the pre-drilled holes located in the corners along the top ledge of the wall panels into the roof (*as shown*). Start with the holes in the left corner of panel 1, from inside place up through the holes just drilled PC-000103 rivets with PC-000121 washers behind the heads of the rivets. While on the outside on top of the roof place PC-000121 washers with PC-000106 back-up washers onto the rivets and rivet into place. Repeat for all corners in each of the panels.

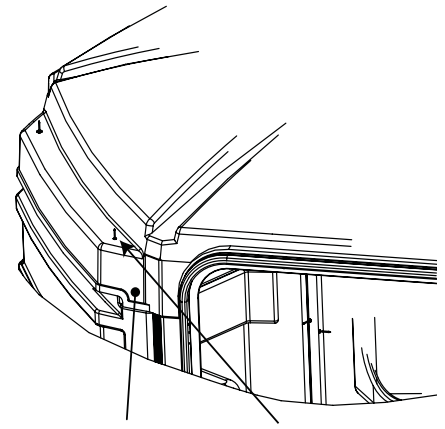

PC-000103 Rivet
front corners to
roof location

PC-000103 Rivet
wall panels to
roof location

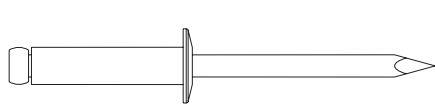

PC-000104 Rivet
(4) Used in this step

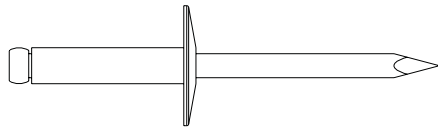

PC-000103 Rivet
(12) Used in this step



PC-000106 Washer
(12) Used in this step

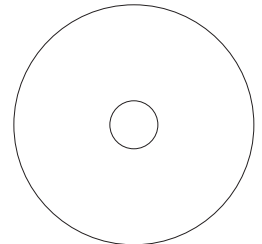

PC-000121 Washer
(22) Used in this step

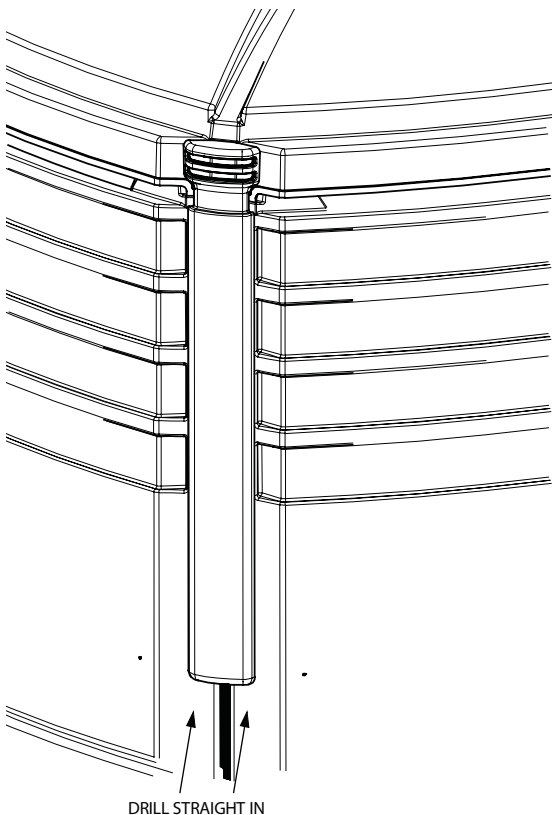

DRILL STRAIGHT IN

STEP 12: Vent Stack

Hold the vent stack against the outside wall joint extrusion between the left two wall panels 1 & 2. Make sure the top of the vent stack is even with the step of the roof (*as shown*). Use a marker and mark on the panels around the two circular vent holes at the bottom of the vent stack. Set the vent stack off to the side. Drill through the panels and the tank in the two locations just marked using a 2-1/4" hole saw. **IMPORTANT: DRILL STRAIGHT TOWARDS THE TANK AND NOT ON AN ANGLE TOWARDS THE PANELS.** Inside the unit, measure up from the tank and mark drill locations on both wall panels at 3", 27" and 53" (*all drill locations will be 1-3/4" away from the wall joint extrusion*). With someone on the outside of the unit holding the vent stack into position, from inside using a 13/64" drill bit, drill through the locations just marked into the vent stack. Rivet the vent stack in place using (6) PC-000105 rivets with (6) PC-000106 washers behind the heads of the rivets.

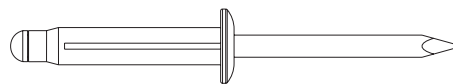

PC-000105 Rivet
(6) Used in this step

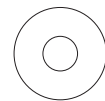

PC-000106 Washer
(6) Used in this step

Step 13: Grab Bar Assembly

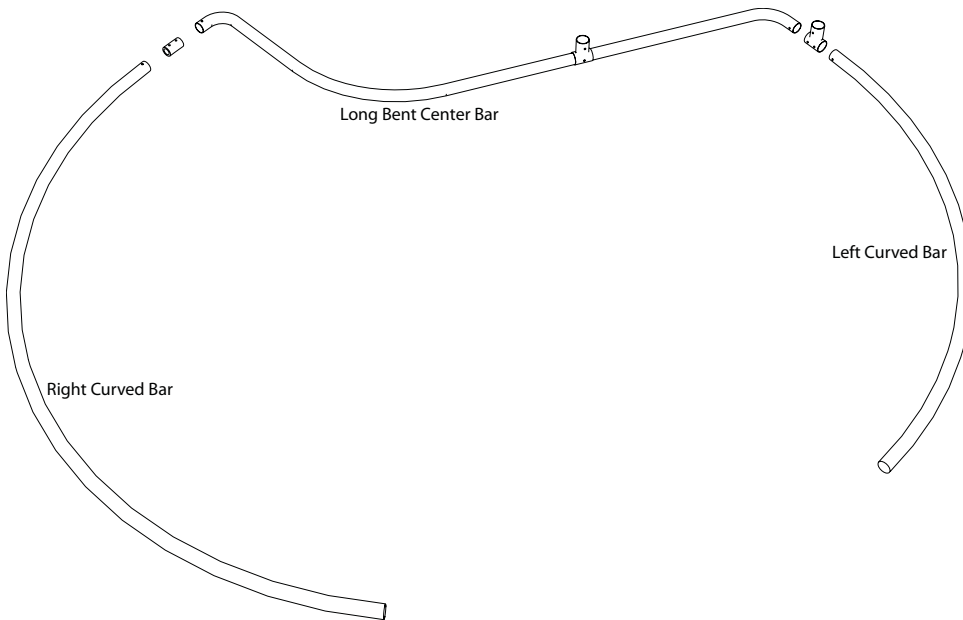

NOTE: All drilling will require a 13/64" drill bit. A.) Outside of the unit lay the three grab bars on the floor upside down (as shown). B.) Take the loose tee and drill three holes on the face of the tee approximately 1/2" from each end of the tee. C.)



Push the loose tee onto the left curved bar and onto the long bent center bar. **NOTE:** Make sure the "tee" is pointing straight upwards. D.) Drill through the pre-drilled holes of the tee into the two bars and rivet in place to both bars with (2) PC-000102 rivets. E.) Insert the plastic internal connector into the long bent center bar (a rubber mallet may be necessary to help tap

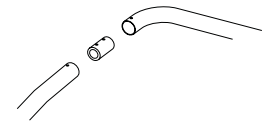

the connector into the bars). Drill a hole approximately 1/2" from the end of the bar into the plastic connector and rivet into place using (1) PC-000104 rivet. F.) Push the right curved bar onto the other end of the plastic connector. Drill a hole approximately 1/2" from the end of the bar into the plastic connector and rivet into place with (1) PC-000104 rivet. G.) Flip the assembly over and take it into the unit placing on top of the grab bar support clips (the grab bar assembly should rest evenly against each side of the door jamb). H.) Push the short vertical support bar into the tee that is connected to the left curved bar (making sure that it is plumb to the tank). Drill through the pre-drilled hole of the tee into the bar and rivet into place with (1) PC-000102 rivet. I.) Push the center vertical support bar into the tee that is connected to the long bent center bar. Position the center vertical support bar 12" from the tank (make sure it is plumb to the floor). Drill two holes through the tee into both bars (making sure holes are centered). Rivet the tee in place to both bars with (2) PC-000102 rivets. J.) Drill a hole up through each of the grab bar support clips into the underside of the grab bars. Drive (5) PC-100175 screws up through the holes just drilled. K.) Pull the ring cover up on the bottom of the short vertical support bar and drill through the four pre-drilled holes of the ring and into the tank. Rivet in place from the topside of the tank using (4) PC-000104 rivets with (4) PC-000106 washers on the inside of the tank. Tap the ring cover back in place. L.) Pull the ring cover up on the bottom of the center vertical support bar and drive (4) PC-000195 self tapping screws through the pre-drilled holes of the ring and into the floor. **NOTE:** Be sure not to overtighten the screws, stripping out the plastic. Tap the ring cover back in place.

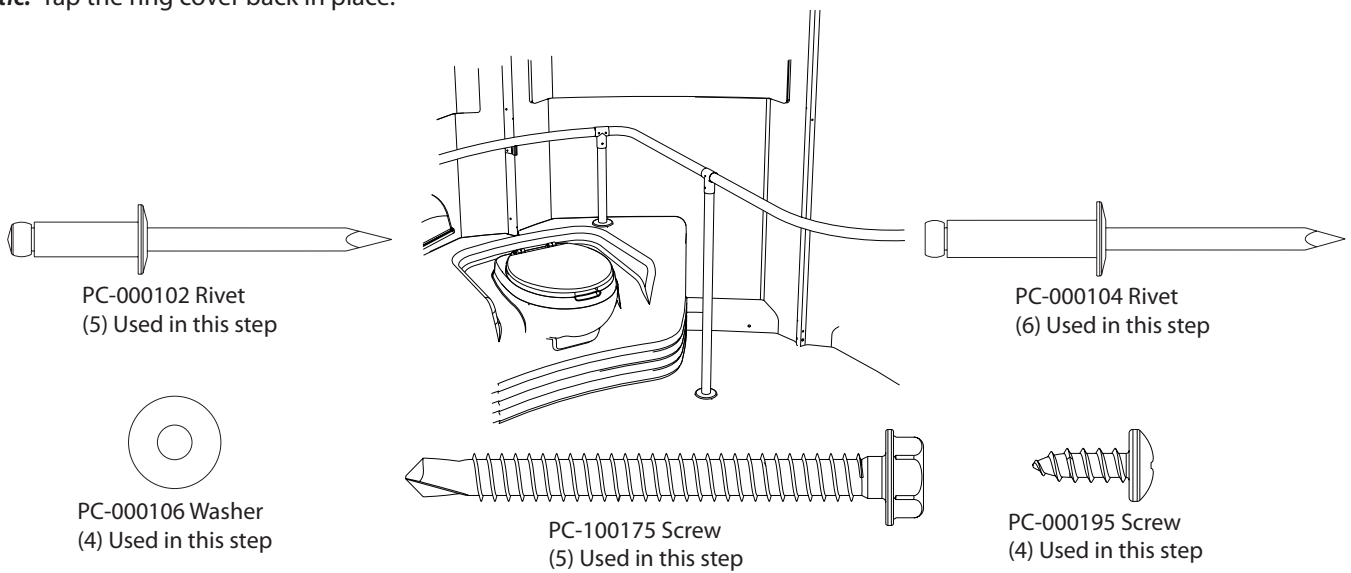

PC-000102 Rivet
(5) Used in this step

PC-000104 Rivet
(6) Used in this step

PC-000106 Washer
(4) Used in this step

PC-100175 Screw
(5) Used in this step

PC-000195 Screw
(4) Used in this step

STEP 14: Grab Bar Fillers

Position the three large fillers behind the grab bars on wall panels 1, 4 & 5. Position the small filler behind the grab bar on panel 2. Using a rubber mallet, hammer the fillers into place behind the grab bars (*as shown*). For the large fillers, on the outside of the unit measure and mark two drill spots. Measure down 4-1/2" from the bottom rib and mark at 10" in across from the corner at both ends of the wall panels. For the small filler, measure and mark two drill spots 4-1/2" down from the bottom rib. Mark the location of the first hole in the center between the vent stack and the corner of the side wall panel. Mark the location of the second hole 10" in from the corner. Using a 13/64" drill bit, drill holes through the drill spots marked on the side walls into the fillers. **NOTE: Be sure to drill through only one wall of the grab bar filler.** On the outside of the unit, rivet the grab bar fillers in place using (8) PC-000105 rivets.

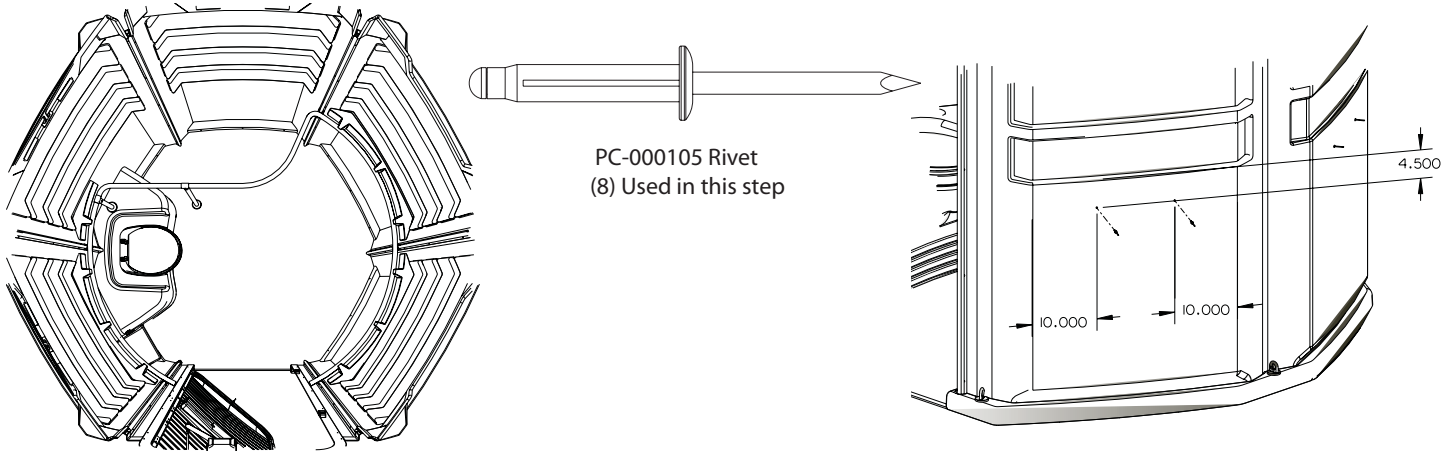

STEP 15: Door Hinges

Lift up the door and line up the pre-drilled holes of the door jamb with the holes in the hinges. Rivet in place using (12) PC-000102 rivets.

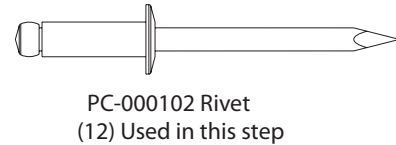

STEP 16: Magnetic Door Assembly

NOTE: Located near the top and bottom of the door frame are pre-drilled holes for the magnetic door assemblies. Make sure the magnet cover is placed against the small spaced side of the magnet assembly with the head of the screw facing out (as shown). Refer to the drawing below for assembly. From the outside insert (2) PC-000107 rivets into the pre-drilled holes of the door jamb, then add the magnet assembly, magnet cover and (2) PC-000106 back-up washers and rivet in place. Repeat for the other magnet catch.

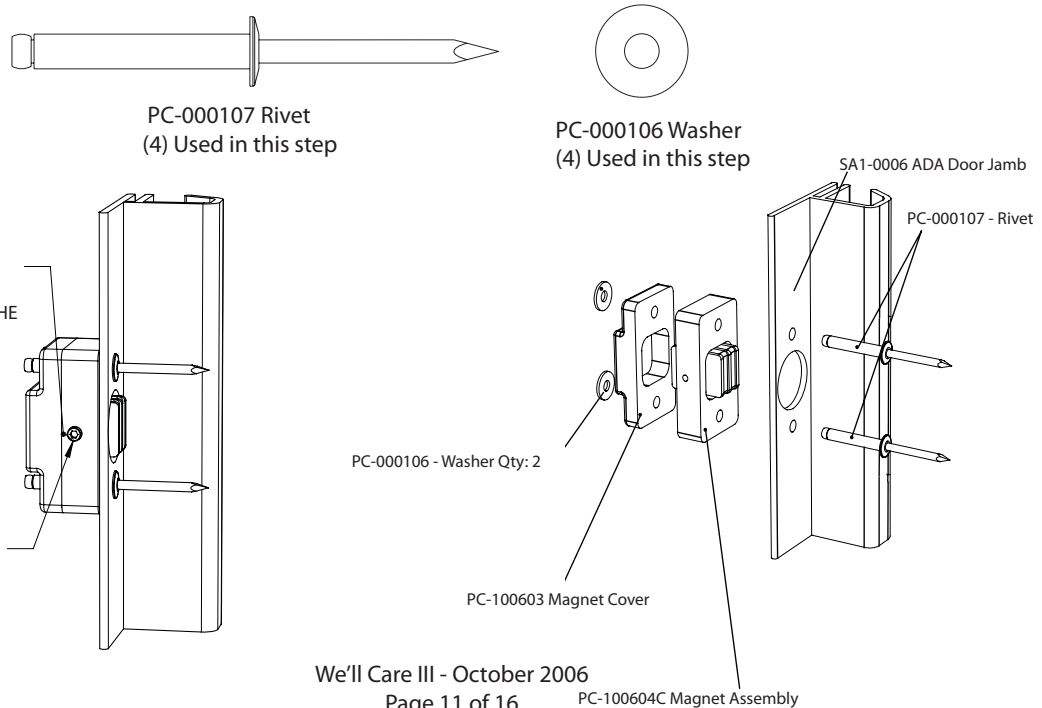

STEP 17: Spring Tube Assembly / Cable Clip Installation

Rivet the PC-000181 cable clip into the pre-drilled holes located in the center of the door jamb using (2) PC-000104 rivets. From the front of the door, insert the PC-000800 spring tube assembly in the outside center molded pocket of the door. Push the ball end of the cable through the 1/2" inch hole to the inside of the door (*making sure that the "boss" in the end cap of the spring assembly is also inserted into this hole*). On the inside of the unit, place the top of a hammer against the PC-000181 cable clip. Place the ball end of the spring cable in the claw of the hammer. Open the door while holding the hammer in position. Hold the door open with your foot, and clamp a vice-grip pliers on the cable where it comes out of the door. **BE SURE TO CLAMP DOWN TIGHT.** Remove the cable from the claw of the hammer, close the door and place the end of the cable into the slot of the cable clip. Open the door and remove the vice-grips.

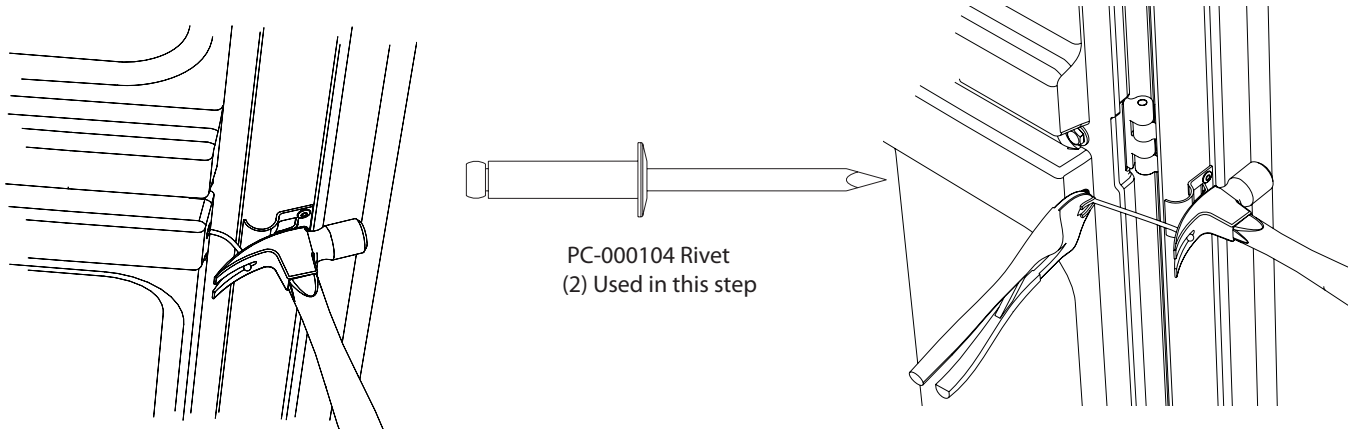

PC-000104 Rivet
(2) Used in this step

STEP 18: Door Panel Cover

Cover the spring tube assembly by positioning the door trim panel into the outside center of the door. Line up the holes of the door trim panel to the pre-drilled holes in the door. Fasten in place from the inside using (6) PC-000163 self tapping screws.

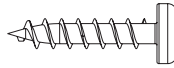

PC-000163 Screw
(6) Used in this step

STEP 19: Outside Door Handle

Place the outside door handle in the right front recess of the door. Fasten in place from the inside using (2) PC-000139 bolts with (2) PC-000121 washers.

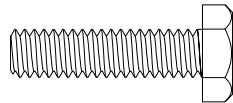

PC-000139 Bolts
(2) Used in this step

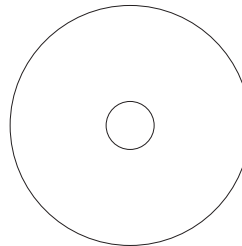

PC-000121 Washer
(2) Used in this step

STEP 20: Slide Latch Assembly / Installation

Fasten the inside door latch handle SA1-0017A to the slide latch SA1-0014 using (2) PC-000166 screws with (2) PC-000106 back-up washers behind the heads of the screws. Place the occupancy decal PC-000780 on the opposite side of the slide latch onto the raised area, lining up the hole in the decal with the hole of the slide latch (*making sure the green/unoccupied end of the decal is facing the tongue end of the slide latch*). Insert the pointed end of a paper clip into the hole of the rubber silencer (*the silencer that is located in the handle area*) and pull out from the frame of the door. Insert the small end of the slide latch retainer SA1-0015 into the slot of the door frame (*directly above the handle area*) and push the slide latch retainer down along the door to the location of the door panel cover. **NOTE: This is a tight fit, a rubber mallet may be used to help push into position.** With the pointed end of a paper clip, push the rubber silencer back into the hole of the door frame where previously removed. Place the tongue of the slide latch into the slot of the slide latch retainer. Position the slide latch retainer against the door. Measure and mark four locations to fasten the slide latch retainer to the door (*two on the top and two on the bottom of the slide latch retainer*). Starting with the top, measure and mark the first location 1/2" away from the door panel and in 1" from the right edge of the slide latch retainer. Mark the second location 1/2" away from the door panel and in 4" from the right edge of the slide latch retainer. Repeat for the bottom locations. Using a 13/64" drill bit, drill through the locations just marked into the door. Rivet into place with (4) PC-000105 rivets.

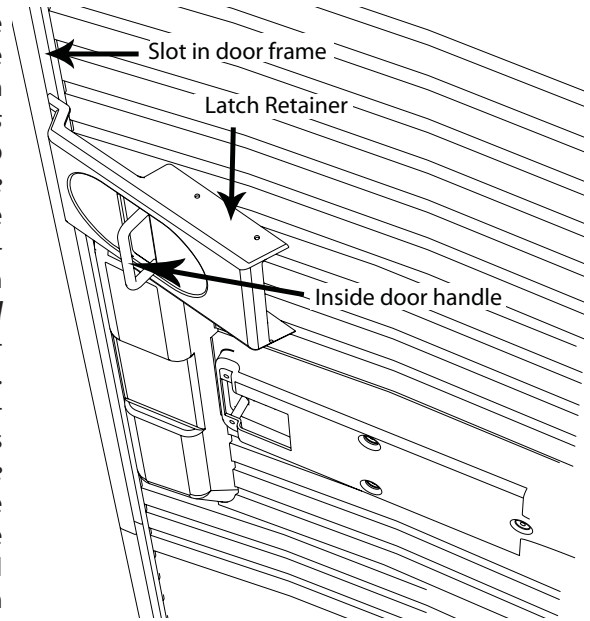

PC-000166 Screw
(2) Used in this step

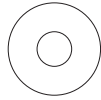

PC-000106 Washer
(2) Used in this step

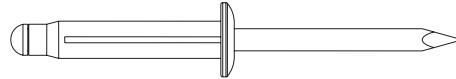

PC-000105 Rivet
(4) Used in this step

STEP 21: Door Check Cable

Locate the first left wall joint extrusion next to the door jamb (*before panel 1*). With a 13/64" drill bit, drill out the very first rivet up from the floor. Line up the bottom hole of the bracket for the door check cable with the hole left from the rivet just drilled out. Rivet a PC-000104 rivet into the bottom hole of the bracket. Using the bracket as a drill guide, drill through the top hole of the bracket into the wall joint extrusion using a 13/64" bit. Rivet in place with a PC-000104 rivet. Place a PC-000106 washer with a PC-000168 washer behind the head of a PC-000104 rivet. Place the looped end of the cable onto the rivet and insert through the pre-drilled hole on the bottom of the door. Add another PC-000106 washer on the inside of the door frame and rivet into place.

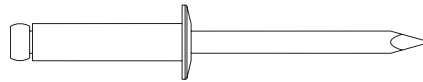
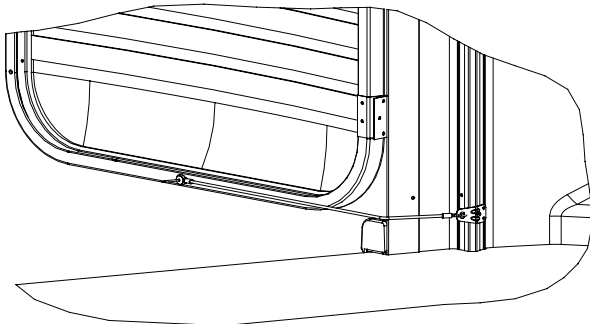

PC-000104 Rivet
(3) Used in this step

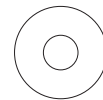

PC-000106 Washer
(2) Used in this step

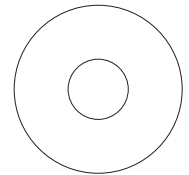

PC-000168 Washer
(1) Used in this step

STEP 22: Ryobi Door Closure Installation

Assemble the arm to the closure body using the screw and washer provided with the door closure.

From inside of the unit rivet the door closure body to the door jamb into the top two pre-drilled holes using (2) PC-000104 rivets. From outside the unit rivet into the bottom two pre-drilled holes (2) PC-000104 rivets with (2) PC-000106 back-up washers on the inside.

Insert the Ryobi bracket into the slot of the aluminum door frame. Rivet in place into the pre-drilled holes with (2) PC-000102 rivets.

Rivet the bracket attached at the end of the Ryobi arm to the Ryobi bracket that is installed on the inside of the door frame with (2) PC-000102 rivets and (2) PC-000106 washers on the inside of the brackets.

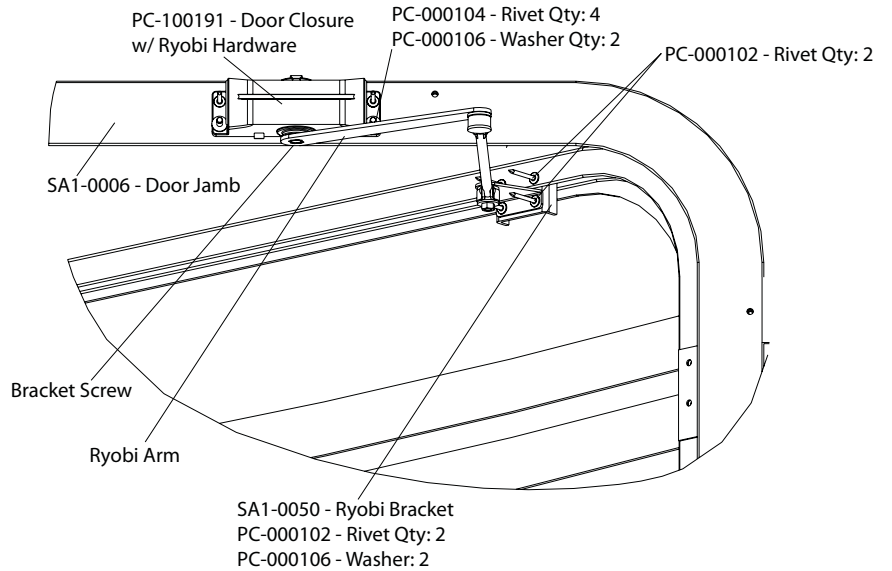

NOTE: To adjust the door closing speed, use a Phillips screwdriver (a sticker with a red arrow on the door closure body indicates that the location of the speed adjustment screw is on the left). Turn the speed adjustment screw clockwise for a slower and counter clockwise for a faster door closing speed. The ADA code requires that the door from an open position of 70 degrees takes at least three seconds to move to a point three inches from the latch measured to the leading edge of the door.

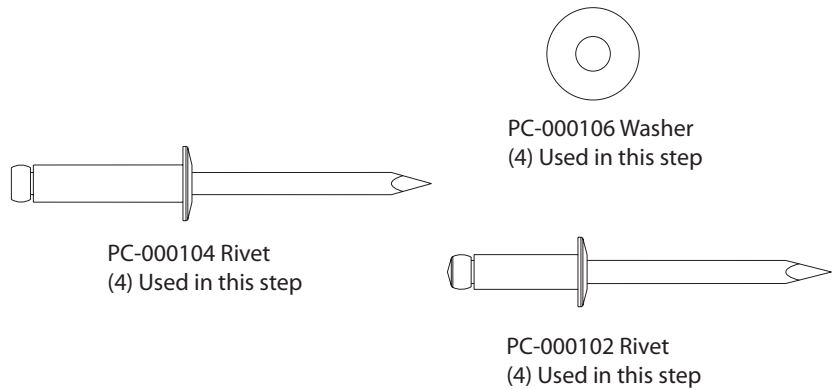

STEP 23: Toilet Paper Dispenser

The toilet paper dispenser is to be mounted on the left wall panel. Level the dispenser on the wall directly below the grab bar filler and to the left of the tank. Use the holes in the back of the dispenser as a guide to mark the drill locations. Drill four 13/64" holes into the drill spots just marked. Rivet in place from the outside using (4) PC-000100 rivets with (4) PC-000106 back-up washers on the inside.

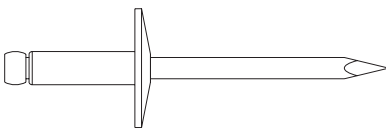

PC-000100 Rivet
(4) Used in this step

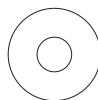

PC-000106 Washer
(4) Used in this step

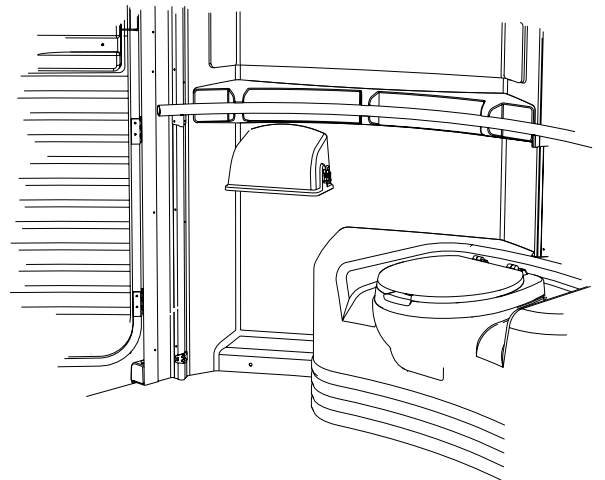

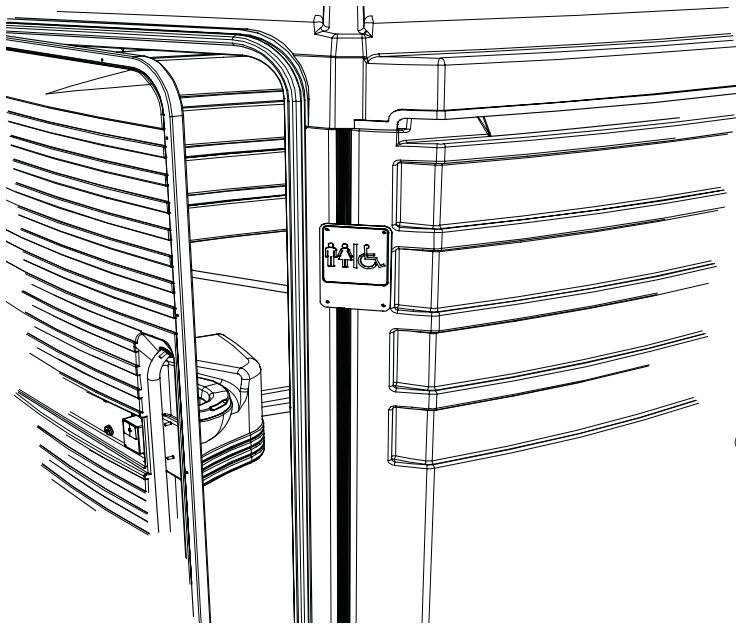

STEP 24: ADA Handicap Sign

Using a drill on slow speed, drill a hole in each corner of the A.D.A. sign SA1-0021 using a 13/64" bit. **IMPORTANT: BE CAREFUL NOT TO BREAK THE SIGN AS IT IS BRITTLE. THE LOCATION OF THE SIGN ON THE UNIT IS CRITICAL. THE BOTTOM OF THE SIGN MUST BE 55-1/2" FROM THE GROUND.** Position the sign so that it is partially on the right door connecting panel and the right corner wall panel. Using the holes in the sign as a drill guide, drill two holes into the door connecting panel and two holes in the right corner of the right wall panel. Rivet from the outside using (4) PC-000102 rivets with (4) PC-000106 back-up washers on the inside.

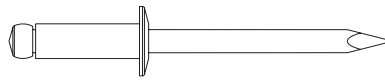

PC-000102 Rivet
(4) Used in this step

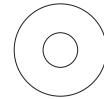

PC-000106 Washer
(4) Used in this step

GENERAL STATISTICS AND USEFUL TECHNICAL INFORMATION

ITEM	STANDARD	METRIC
FRESH WATER	1 gal	3.785 ltr
One gal	128 fl. oz	3,780 ml
One qt	32 fl. oz	946.35 ml
One gal	8.33 lb	3.75 kg
SEWAGE		
One gal	10.20 lb	4.59 kg
Feces per person per day*	.5 lb (26.12 fl. oz)	.23 kg (772.4 ml)
Urine per person per day*	1 qt (32 fl. oz)	.95 ltr
Average person urination at special events = 8 - 10 fl. oz (237 - 296 ml)	9 fl. oz / average	266 ml / average
* per Portable Sanitation Association International (PSAI)		
NOTE: Weather conditions and consumption of foods, liquids and alcoholic beverages can increase usage by 30 to 40%		