



POLYJOHN®

SAN2-1001 PJ Sanitizer SAN2-1002 Foaming Sanitizer E SaniStand® Hand Sanitizer Stand Assembly Instructions

SAN2-1000 STAND SPECIFICATIONS

<u>Dimension</u>	<u>Imperial</u>	<u>Metric</u>
Height	52 in	132 cm
Width	29.5 in	75 cm
Depth	29.5 in	75 cm
Weight Empty	17 lb	7.71 kg

PSD1-1000 DISPENSER SPECIFICATIONS

<u>Dimension</u>	<u>Imperial</u>	<u>Metric</u>
Height	6.5 in	16.5 cm
Width	4.5 in	11.7 cm
Depth	4.5 in	11.7 cm
Capacity	30 oz	887 ml
Amount Dispensed per push	.034 oz	1 ml

FD1-1000 DISPENSER SPECIFICATIONS

<u>Dimension</u>	<u>Imperial</u>	<u>Metric</u>
Height	11 in	28 cm
Width	6.4 in	16.25 cm
Depth	7.5 in	19 cm
Capacity	27 oz	800 ml

NOTE: All dimensions are subject to change due to environmental factors.

The E-Sanistand stores flat, can be easily assembled/disassembled, and is a great answer to an immediate need for hand sanitation. The mounting face of the stand can accommodate dispensers up to 6.70 in. (17 cm) wide. The unit can be assembled with the smooth finish out or a textured finish out. This unit comes with 2 - PSD1-1000 Soap/Sanitizer dispensers. To mount the dispensers, you will need a drill with a 3/16" bit and a screwdriver and 3/8" wrench (if using the screws) or rivet gun (if using the rivets)

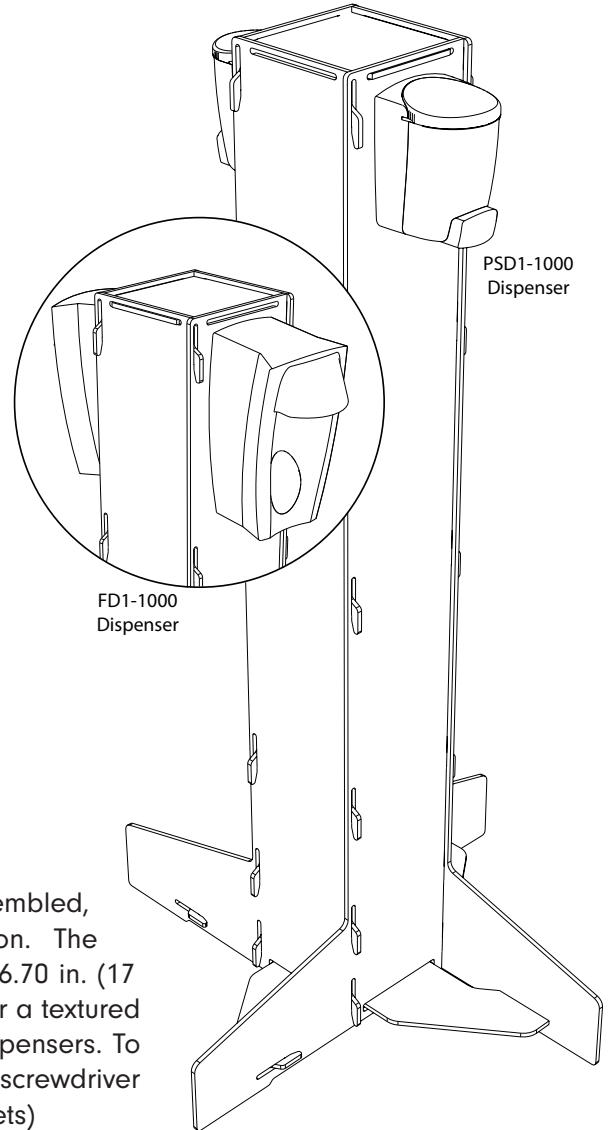

POLYJOHN USA

PolyJohn Enterprises Corp
2500 Gaspar Ave.
Whiting, IN 46394
Phone: 800-292-1305
Fax: 219-659-0625
www.polyjohn.com
info@polyjohn.com

POLYJOHN WORLDWIDE

PolyJohn (UK) Ltd.
Equinox 1 Audby Lane
Wetherby, England LS22 7RD
Phone: 44 (0) 1937-583333
Fax: 44 (0) 1937-583322
www.polyjohn.co.uk
sales@polyjohn.co.uk

POLYJOHN CANADA

PolyJohn Canada
P.O. Box 2300
199 Forest Plain Rd.
Orillia, Ontario LV3 6S2
Phone: 800-465-9590
Fax: 705-325-8250
www.polyjohncanada.ca
info@polyjohncanada.ca

We recommend reading through the entire booklet prior to proceeding with use, service or maintenance.

Assembly Instructions

Step 1: Insert the tabs of one panel into the slots of a second panel and slide down into place. Repeat this step for the remaining panels.

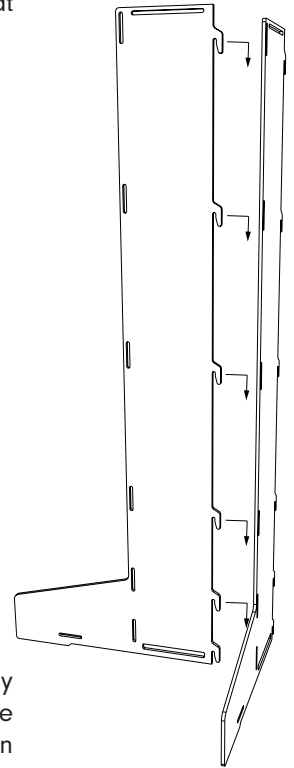
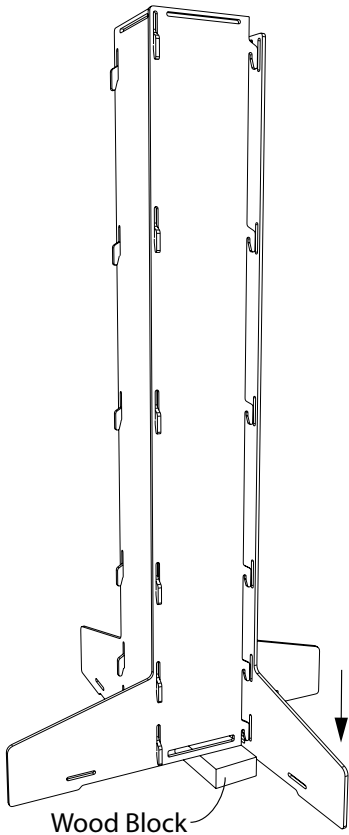

Step 2: For the final panel, You will need to twist the whole assembly to get the last tabs into the slots. To do this, place your foot or a piece of a 2 x 4 wood block under the panel with the tabs and push down on the panel with the slots. Place the bottom tab partially into the bottom slot but do not fully install it. This will hold the two panels into alignment and enable you to insert the remaining tabs into their corresponding slots. Once you have all the tabs inserted, you can 'pop' the tabs through the slots and the unit will fully engage.

Step 3: Slide the leg brace into the slots located at the bottom of the panels and insert the tabs into the corresponding slots. Pull the tab into the slots. Repeat this for the other leg brace. You will have to guide the second brace under the first brace and into the slot of the side panel.

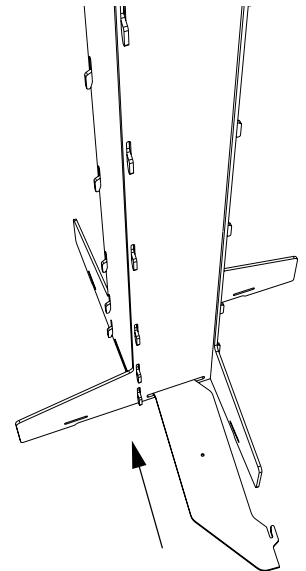
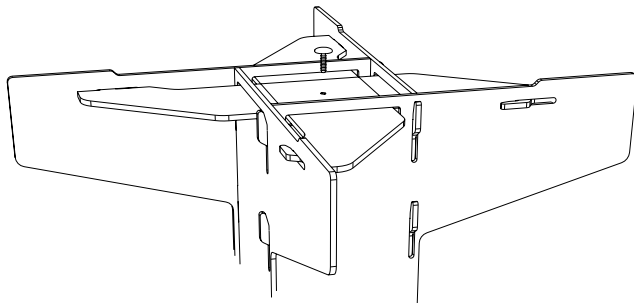

Step 4: Turn the unit upside down and line up the pre-drilled holes in the two leg braces. Fasten into place using the supplied PC-000369 plastic fastener

Step 5: Stand the unit upright. If you want to add a ballast of some sort (sandbag, gallon jug(s) of water/sand), do that now by sliding the ballast down into the center of the Sani Stand.

Assembly Instructions Cont.

Dispenser Installation

(See included instruction sheet if installing the FD1-1000 Foam Dispenser)

Step 6: Remove the lid by turning counterclockwise and lift up.

Step 7: Push the locking tab back and lift up on the dispenser container.

Step 8: Holding the backing plate in the place where you would like to mount the dispenser, mark the placement for the three mounting holes. Use a drill with a 3/16" drill bit to drill the holes in the marked spots.

Step 9: Secure the backing plate in place using the desired fasteners. If riveting, please rivet from the outside using the PC-000104 rivets with PC-000106 washers on the inside. If using the PC-000229 screws, insert the screw through the backing plate and apply a PC-000106 washer and PC-000230 nut on the inside. Tighten in place using a phillips screwdriver with 3/8" wrench.

Step 10: Slide the liquid container back in place, making sure the locking tab is in place, and fill with desired soap or hand sanitizing solution. If the dispenser is fitted with a foaming pump, only foaming soap/hand sanitizing solution may be used.

Step 11: Replace the lid and secure in place by turning clockwise.

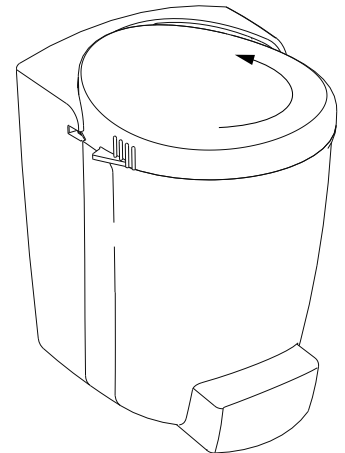

1) Push In Tab

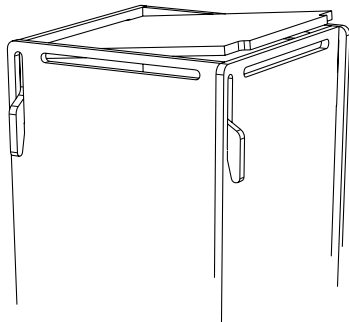
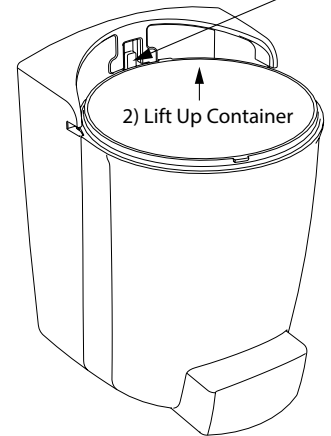

Step 12: Insert the tab on the top panel into one of the slots at the top of one of the sides. Using a screwdriver or other tool to pry with, pry the opposite side out so that the tab will insert into the corresponding slot.

Maintenance and Care

- Use only mild cleaners with no abrasives using a soft cloth to clean all surfaces.
- Some silicone grease should be applied occasionally to the o-ring at the top of the soap container to keep the lid from sticking. Mineral oil should NEVER be used.
- If there is a chance for freezing, remove the dispenser and drain the soap. Be sure to remove the soap from the pump as well.
- All testing and statements thereof pertain to PolyJohn approved chemicals. Any results of non-approved chemicals to PolyJohn products are the responsibility of the customer.

Assembly is complete

OUR MISSION STATEMENT

"PolyJohn is a family owned, state of the art, plastics manufacturing company dedicated to providing its employees with a work environment committed to excellence, and its customers with innovative products, services and technology that meet or exceed their requirements."

THANK YOU FOR PURCHASING POLYJOHN PRODUCTS!

**For a video demonstration of assembly and more product information, visit
www.polyjohn.com/emergency-sanistand**

For more products and information, visit
www.PolyJohn.com

2500 Gaspar Ave., Whiting, IN 46394

SAN2-1001/SAN2-1002 Assembly - May 2020

Page 3 of 4

